

**CASE IH STEIGER 350, 400, & 450 (2012 AND LATER) WITH CAST BUMPER  
NEW HOLLAND T9.390, T9.450, T9.505, T9.560 WITH CAST BUMPER  
TRACTOR STALK STOMPER  
INSTALLATION**

**Safety Recommendations:**

Prior to installation, removal or maintenance of May Wes Stalk Stompers, park tractor on level ground and lock the brakes. In addition, please follow all safety recommendations listed in the OEM owner's manual.

**Installation:**

- 1) Lower cast bumper by loosening bolts. Complete removal of cast bumper will not be necessary.
- 2) Remove toolbox brackets. Set aside M12 hardware for use with new brackets.
- 3) Mount bracket #22680 Right Mount Bracket to the right side of tractor. Reuse existing M12 hardware to mount bracket. Do not tighten bracket until full assembly is almost complete.
- 4) Mount bracket #22681 Left Mount Bracket to the left side of tractor. Reuse existing M12 hardware to mount bracket. Do not tighten bracket until full assembly is almost complete.
- 5) Place #22712 shim plate around boss on cast bumper on both sides.
- 6) Start tightening bolts for cast bumper. During this process, ensure that the mount brackets and shims stay centered on boss hole of cast bumper. Before final tightening of cast bumper hardware, tighten hardware for mount brackets.
- 7) Proceed to mounting the Lift Arm Assemblies using 3/4" hardware supplied with mount kit and instructions provided with each Lift Arm Kit.
- 8) Reference page 2 for Stalk Stomper positioning and mounting using the 1/2" hardware supplied with mount kit.

\* All orientation references are from the operators position.

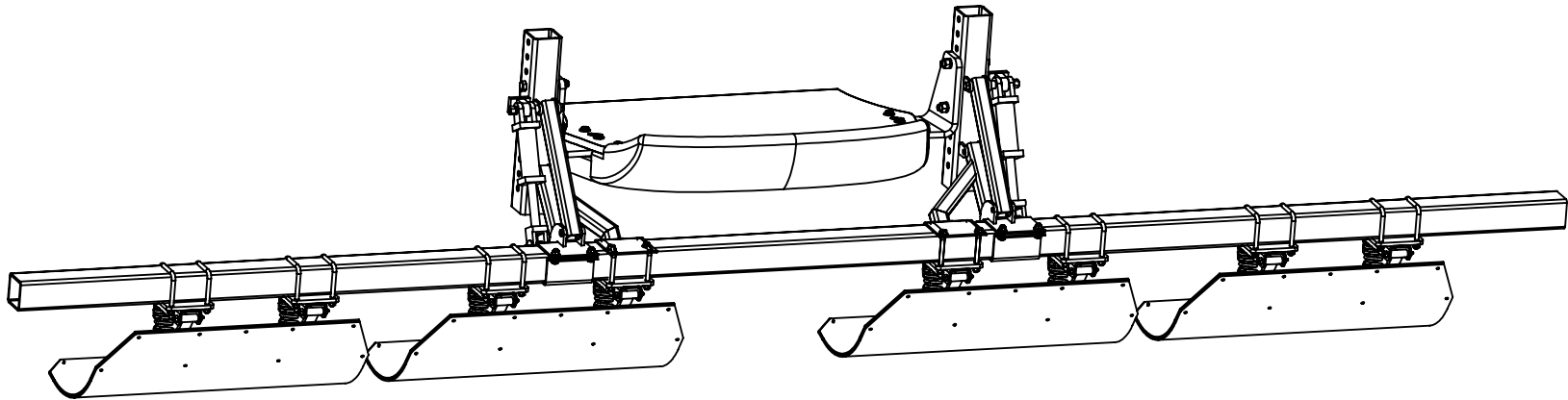

**MAY WES**  
*Original Poly People*  
A DIVISION OF PRIDE SOLUTIONS

120 Eastgate Drive SE  
PO Box 7  
Hutchinson, MN 55350

1-800-788-6483  
1-320-587-2322  
1-320-587-6112 (Fax)

[WWW.MAYWES.COM](http://WWW.MAYWES.COM)

**CASE IH STEIGER 350, 400, & 450 (2012 AND LATER) WITH CAST BUMPER  
NEW HOLLAND T9.390, T9.450, T9.505, T9.560 WITH CAST BUMPER  
TRACTOR STALK STOMPER  
PARTS LISTING**

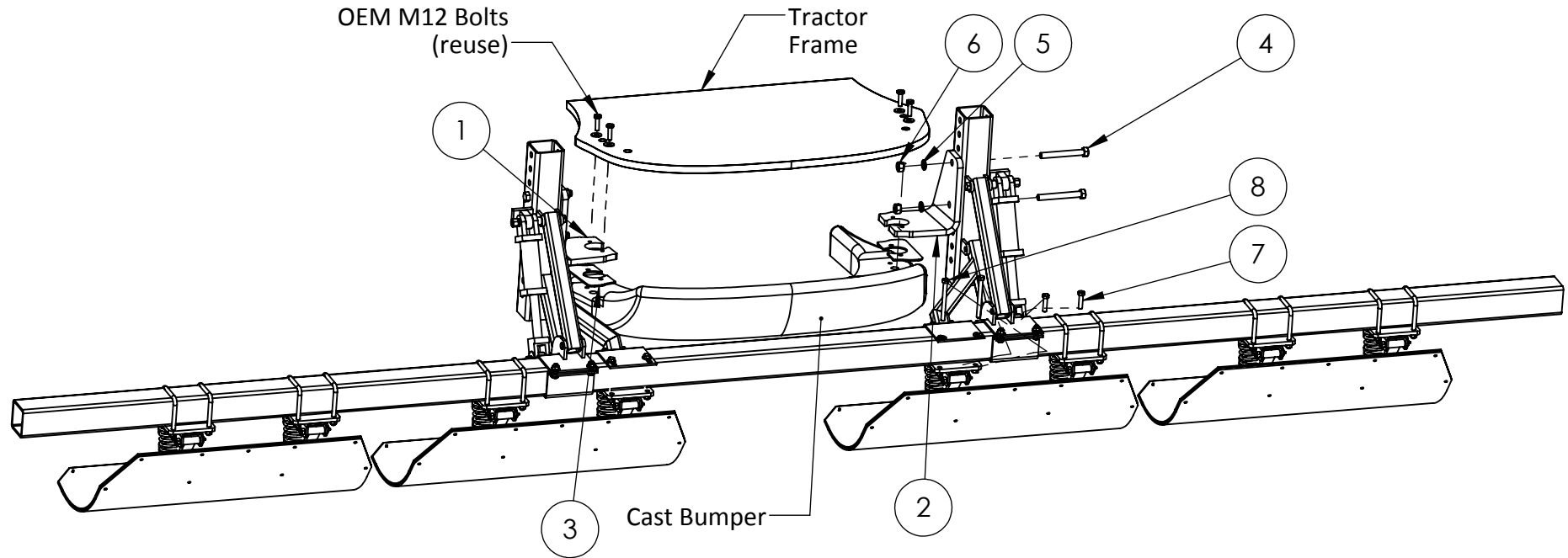

ITEM#	PART#	DESCRIPTION	QTY
1	22680	MOUNT PLATE (RIGHT)	1
2	22681	MOUNT PLATE (LEFT)	1
3	22712	SHIM	2
4	00033	BOLT, 3/4"-10 X 6" HEX	4
5	00237	WASHER, 3/4" SPRING LOCK	4
6	00199	NUT, 3/4"-10 HEX	4
7	00146	BOLT, 1/2"-13 X 2 HEX	4
8	00156	BOLT, 1/2"-13 X 5-1/2" HEX	4

**NOTES:**

- 1 Graphics are for reference only and do not represent final assembled height.



120 Eastgate Drive SE  
PO Box 7  
Hutchinson, MN 55350

1-800-788-6483  
1-320-587-2322  
1-320-587-6112 (Fax)

[WWW.MAYWES.COM](http://WWW.MAYWES.COM)

**OPTIONAL TOOLBOX MOUNTING  
(HARDWARE NOT INCLUDED)**



**MAY WES**  
*Original Poly People*  
A DIVISION OF PRIDE SOLUTIONS

120 Eastgate Drive SE  
PO Box 7  
Hutchinson, MN 55350

1-800-788-6483  
1-320-587-2322  
1-320-587-6112 (Fax)

[WWW.MAYWES.COM](http://WWW.MAYWES.COM)