

DRAGO GT QD2 TOOLBAR MOUNT STALK STOMPER

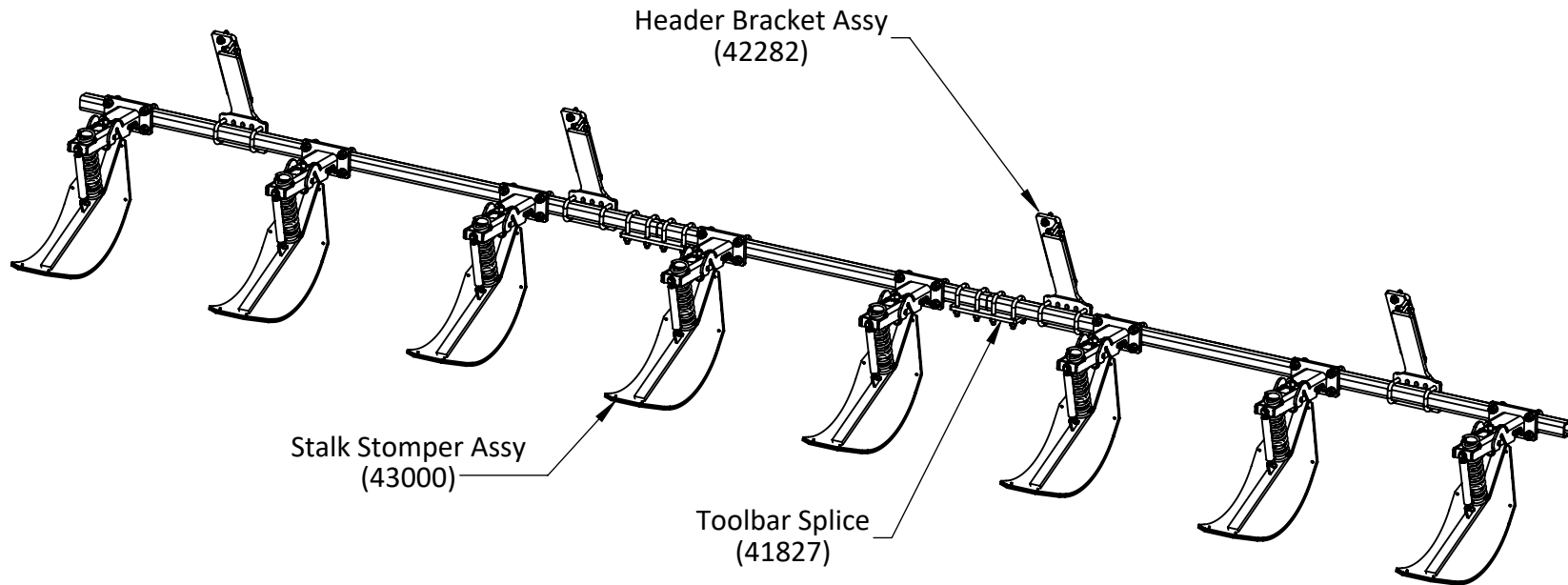

Notes:

- Illustration shown is for reference purposes only. Quantities and components will vary. Please refer to individual component parts listings for specific information.
- Due to variation of implement configurations, row coverage under the feeder house may not be applicable.
- * Toolbar is not included in all kits. If a kit without Toolbar was ordered, the customer is responsible for providing required Toolbar.



MAY WES
Original Poly People
A DIVISION OF PRIDE SOLUTIONS

120 Eastgate Drive SE
PO Box 7
Hutchinson, MN 55350

1-800-788-6483
1-320-587-2322
1-320-587-6112 (Fax)

WWW.MAYWES.COM

DRAGO GT HEADER BRACKET INSTALLATION



Figure 1



Figure 3



Figure 2

Installation Procedure:

- Park combine on level ground and lock the brakes.
- Raise the head and lock in the upright position.
- Mount the Header Brackets to the vertical frame supports (figure 1) on the rear of the corn head using the M12 Hex Flange bolts supplied (figure 2)
- Install Vertical Brackets onto Header Brackets and secure in place with supplied bolts, washers, and nuts (figure 3)
- Refer to the Toolbar Mount Stalk Stomper Instructions to continue installation.



120 Eastgate Drive SE
PO Box 7
Hutchinson, MN 55350

1-800-788-6483
1-320-587-2322
1-320-587-6112 (Fax)

WWW.MAYWES.COM

DRAGO GT TOOLBAR MOUNT STALK STOMPER ASSEMBLY INSTRUCTIONS / PARTS LISTING

ITEM #	PART #	DESCRIPTION	QTY.
1	22702	MOUNT BRACKET	1
2	42284	VERTICAL BRACKET	1
3	00986	U-BOLT 1/2"-13	2
4	00255	WASHER, 1/2" SPRING LOCK	6
5	00214	NUT, 1/2"-13 HEX	6
6	00146	BOLT, 1/2"-13 X 2 HEX	2
7	01086	BOLT, M12X1.75X40MM 8.8	3

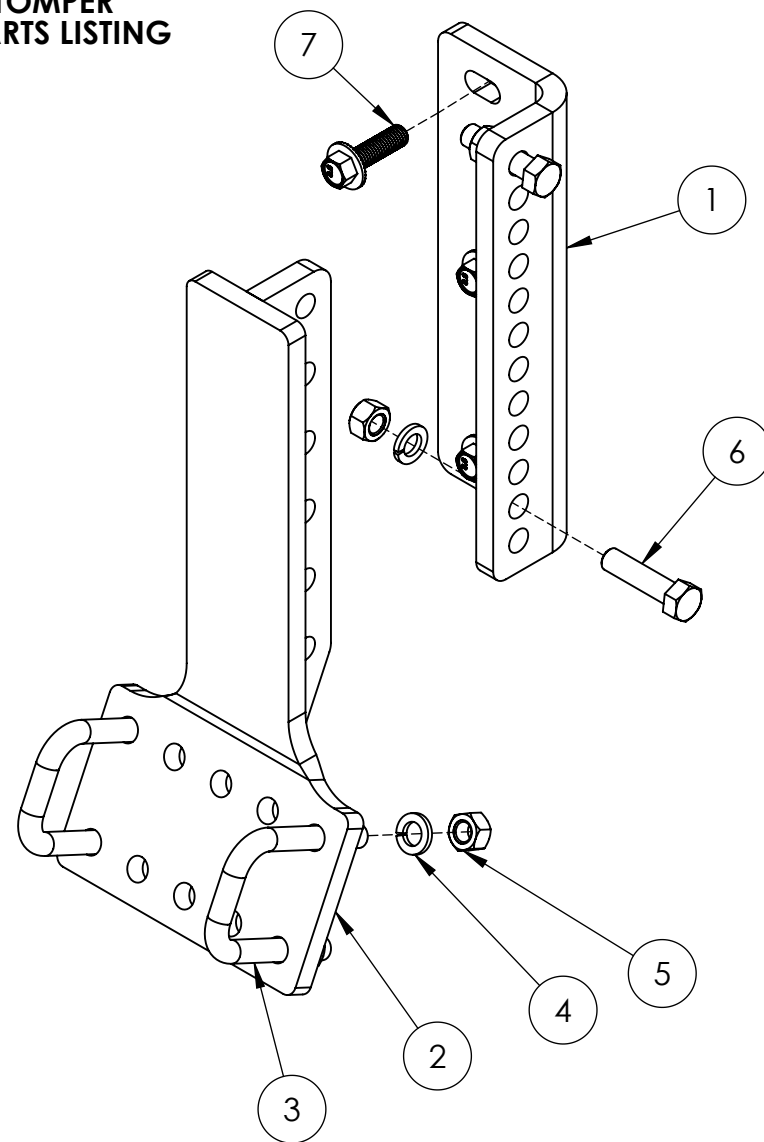

MAY WES
Original Poly People
A DIVISION OF PRIDE SOLUTIONS

120 Eastgate Drive SE
PO Box 7
Hutchinson, MN 55350

1-800-788-6483
1-320-587-2322
1-320-587-6112 (Fax)

WWW.MAYWES.COM