

Case IH 900 / 1000 Series G4 TOOLBAR MOUNT STALK STOMPER

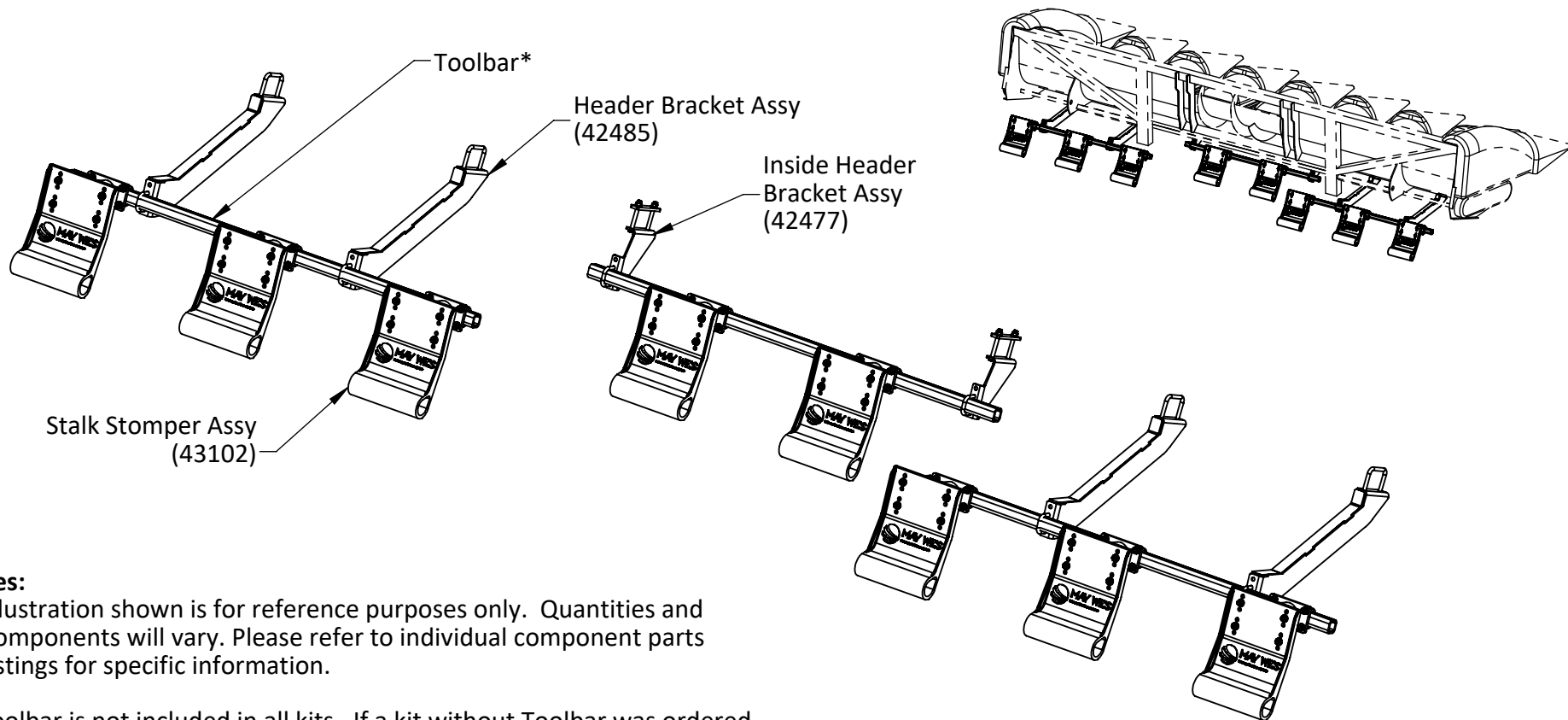

CAUTION

PLEASE REFER TO YOUR EQUIPMENT MANUFACTURER'S OPERATORS MANUAL FOR PERTINENT SAFETY PRECAUTIONS



Notes:

- Illustration shown is for reference purposes only. Quantities and components will vary. Please refer to individual component parts listings for specific information.

* Toolbar is not included in all kits. If a kit without Toolbar was ordered, the customer is responsible for providing required Toolbar.



120 Eastgate Drive SE
Hutchinson, MN 55350

1-800-788-6483
1-320-587-2322
1-320-587-6112 (Fax)

WWW.MAYWES.COM

Case IH 900 / 1000 Series
G4 TOOLBAR MOUNT STALK STOMPER

6 Row Head

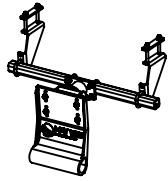

6 Row Head
2 Row Layout

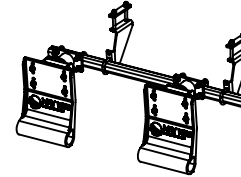
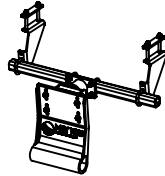

6 Row Head
4 Row Layout

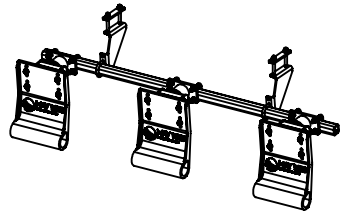
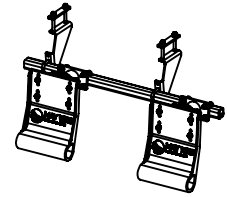

6 Row Head
6 Row Layout

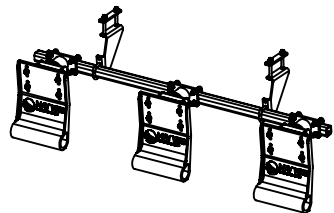

Case IH 900 / 1000 Series
G4 TOOLBAR MOUNT STALK STOMPER

8 Row Head

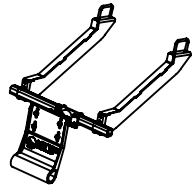

8 Row Head
2 Row Layout

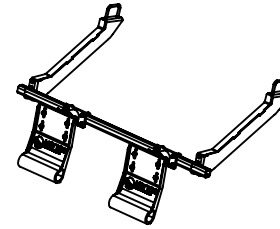
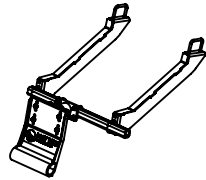

8 Row Head
4 Row Layout

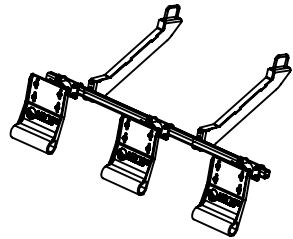
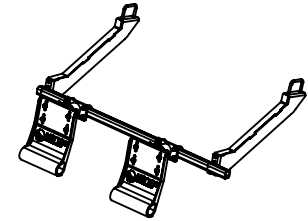

8 Row Head
6 Row Layout

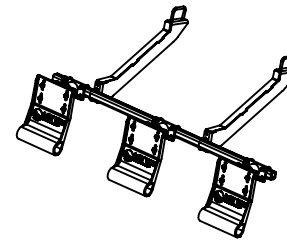
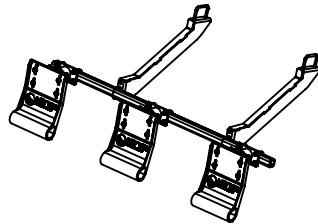

8 Row Head
8 Row Layout

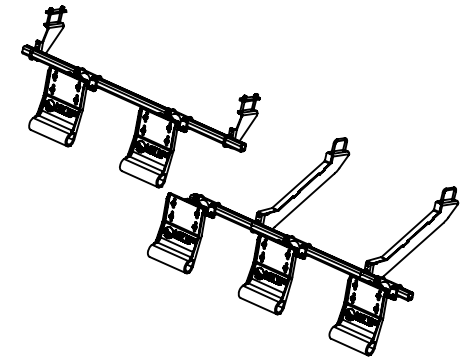

MAY WES
Original Poly People
A DIVISION OF PRIDE SOLUTIONS

120 Eastgate Drive SE
Hutchinson, MN 55350

1-800-788-6483
1-320-587-2322
1-320-587-6112 (Fax)

WWW.MAYWES.COM

Case IH 900 / 1000 Series G4 TOOLBAR MOUNT STALK STOMPER

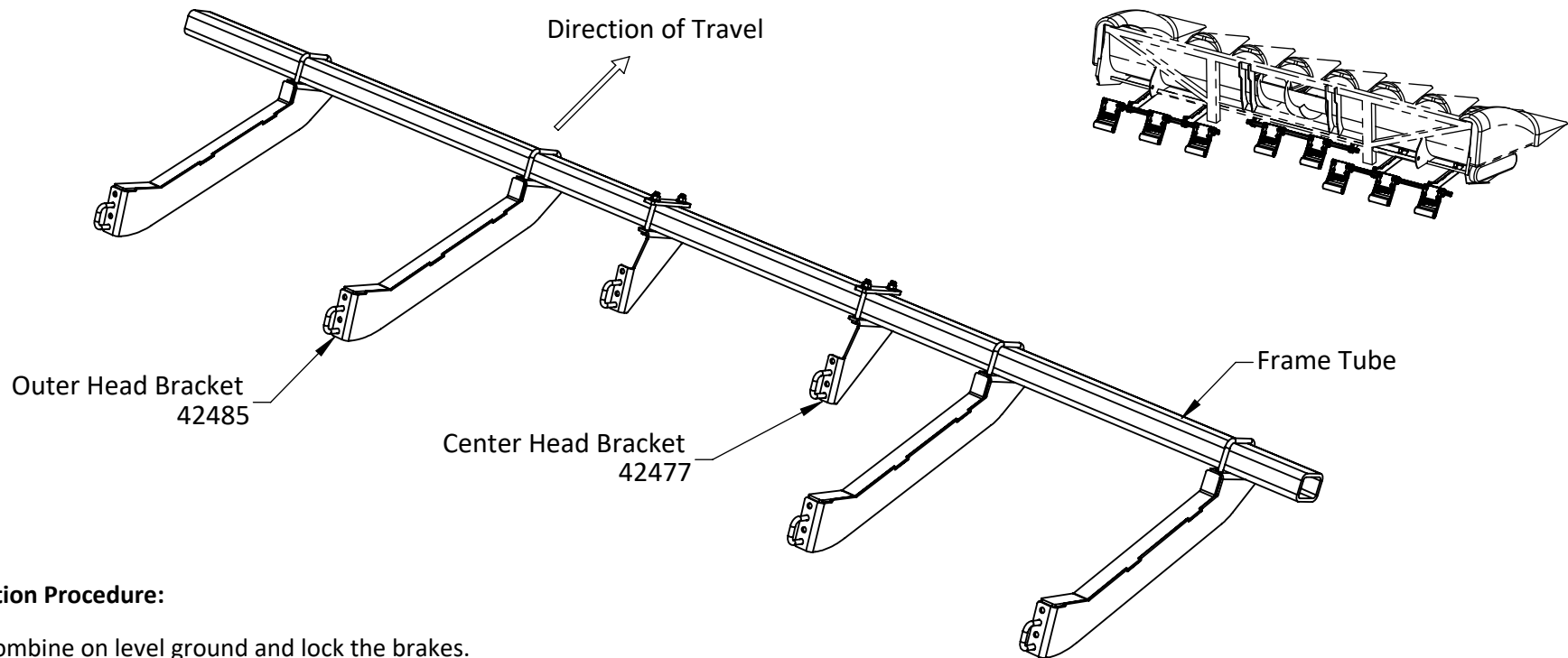

Installation Procedure:

- Park combine on level ground and lock the brakes.
- Raise the head and lock in the upright position.
- Mount the Outer Header Brackets (42485) and Inner Header Brackets (42477) to the 3" x 4" frame beam on the bottom of the corn head. Place the U-Bolts over the top of the frame beam.
- Position the Header Brackets, between the row units.
 - It is suggested that a Header Bracket be placed inside the outer most row units on each side of the head
 - It is suggested that a Header Bracket be placed between row units, just outside of the feeder house of the combine.
 - Keep as much distance between brackets as possible.

Note: Locations may vary depending on the model.



120 Eastgate Drive SE
Hutchinson, MN 55350

1-800-788-6483
1-320-587-2322
1-320-587-6112 (Fax)

WWW.MAYWES.COM

Case IH 900 / 1000 SERIES G4 TOOLBAR MOUNT STALK STOMPER

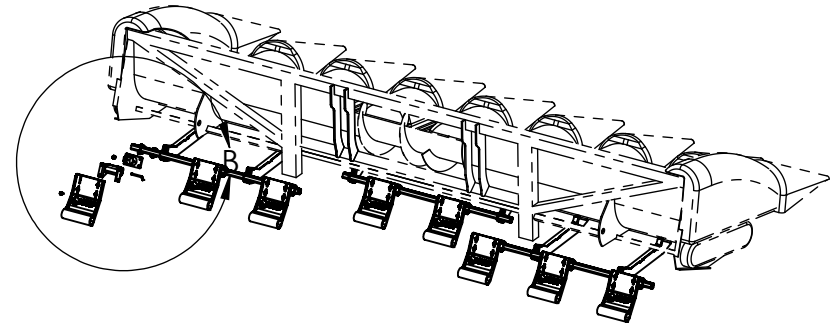
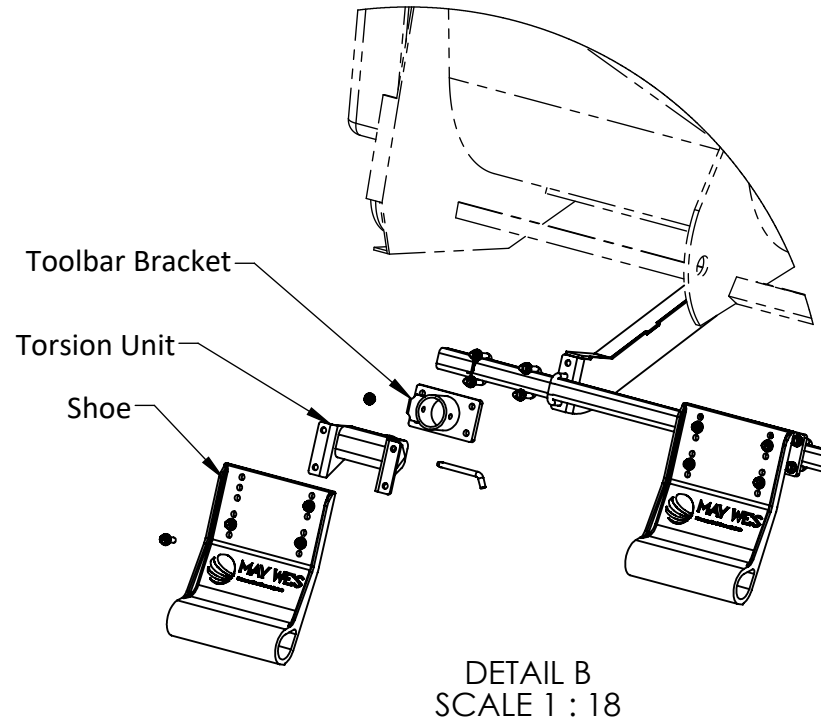

Installation Procedure:

- On flat ground, lower the head to approximate working height.
- Attach Toolbar Brackets (42298) using U-Bolts and nuts, behind the center of each row to be stomped.
- Lift Stalk Shoe Assembly into mating features on the mounting bracket and attach with pin and clip.
- Height can be adjusted by repositioning the shoe to the torsion unit. Each set of holes will adjust the height by 1"

NOTE:

Refer to G4 Stalk Stomper Instruction (Document 10274) for Setup, Operation, Maintenance, Transport and Storage Instructions



120 Eastgate Drive SE
Hutchinson, MN 55350

1-800-788-6483
1-320-587-2322
1-320-587-6112 (Fax)

WWW.MAYWES.COM

**Case IH 900 / 1000 SERIES
G4 TOOLBAR MOUNT STALK STOMPER**

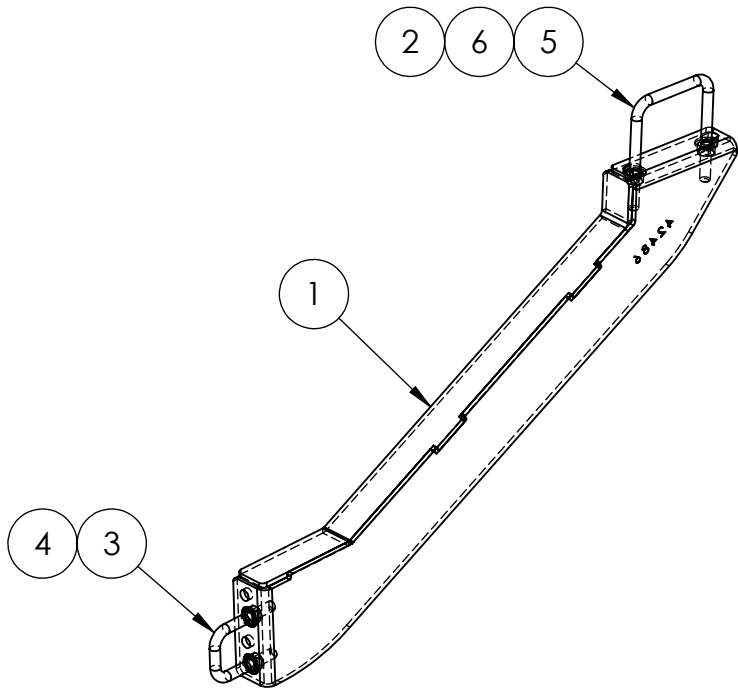

42485 - Outer Header Bracket

| | | | |
|--------|--------|-------------------------|------|
| 6 | 00253 | WASHER, 1/2" SAE FLAT | 2 |
| 5 | 00965 | U-BOLT 1/2"-13 x 4" | 1 |
| 4 | 00730 | NUT, 1/2"-13 HEX FLANGE | 2 |
| 3 | 00986 | U-BOLT 1/2"-13 X 2" | 1 |
| 2 | 00216 | NUT, 1/2" NC TOP LOCK | 2 |
| 1 | 42486 | ARM, CIH 1083 OUTER G4 | 1 |
| ITEM # | PART # | DESCRIPTION | QTY. |

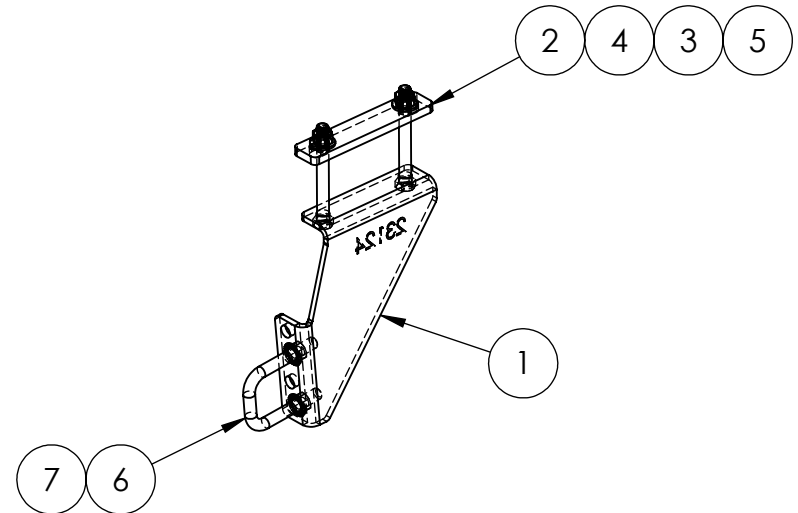

42477 - Center Header Bracket

| | | | |
|--------|--------|----------------------------|------|
| 7 | 00730 | NUT, 1/2"-13 HEX FLANGE | 2 |
| 6 | 00986 | U-BOLT 1/2"-13 X 2" | 1 |
| 5 | 00216 | NUT, 1/2" NC TOP LOCK | 2 |
| 4 | 00153 | BOLT, 1/2 - 13UNC X 4-1/2" | 2 |
| 3 | 00253 | WASHER, 1/2" SAE FLAT | 2 |
| 2 | 23020 | STRAP, JD 40/90 MNTG | 1 |
| 1 | 23124 | BRACKET, CIH 900/1000 G4 | 1 |
| ITEM # | PART # | DESCRIPTION | QTY. |



120 Eastgate Drive SE
Hutchinson, MN 55350

1-800-788-6483
1-320-587-2322
1-320-587-6112 (Fax)

WWW.MAYWES.COM

Case IH 900 / 1000 SERIES G4 TOOLBAR MOUNT STALK STOMPER

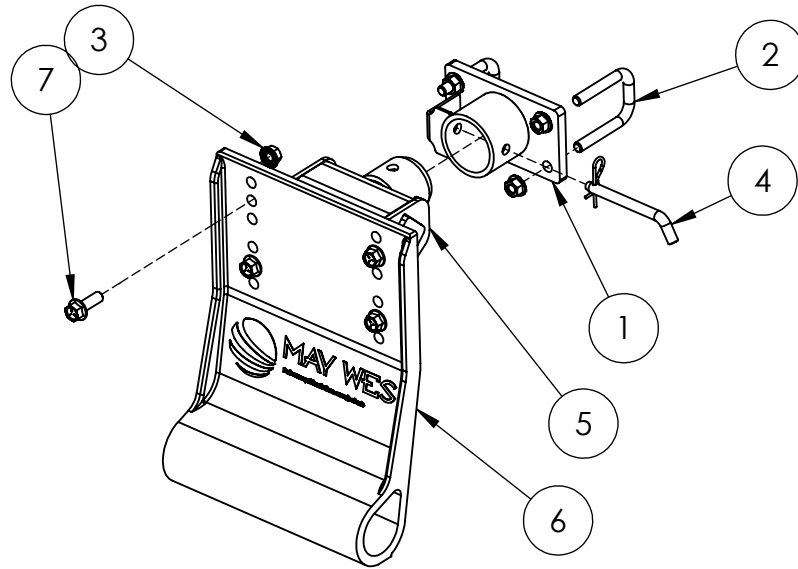

43102 - Stalk Stomper Shoe Assembly

| | | | |
|--------|--------|-----------------------------------|------|
| 7 | 00729 | BOLT, 1/2"-13 X 1-1/2" HEX FLANGE | 4 |
| 6 | 24100 | SHOE, G4 MOLDED | 1 |
| 5 | 42295 | STALK STOMPER TORSION ASSY | 1 |
| 4 | 01130 | PIN, 1/2" X 4" BENT HITCH | 1 |
| 3 | 00730 | NUT, 1/2"-13 HEX FLANGE | 8 |
| 2 | 00986 | U-BOLT 1/2"-13 X 2" | 2 |
| 1 | 42298 | WLDMT; TOOLBAR MNT BRKT | 1 |
| ITEM # | PART # | DESCRIPTION | QTY. |



120 Eastgate Drive SE
Hutchinson, MN 55350

1-800-788-6483
1-320-587-2322
1-320-587-6112 (Fax)

WWW.MAYWES.COM