

MACDON C SERIES G4 TOOLBAR MOUNT STALK STOMPER



CAUTION

PLEASE REFER TO YOUR EQUIPMENT MANUFACTURER'S OPERATORS MANUAL FOR PERTINENT SAFETY PRECAUTIONS



IMPORTANT

Read all instructions before starting installation

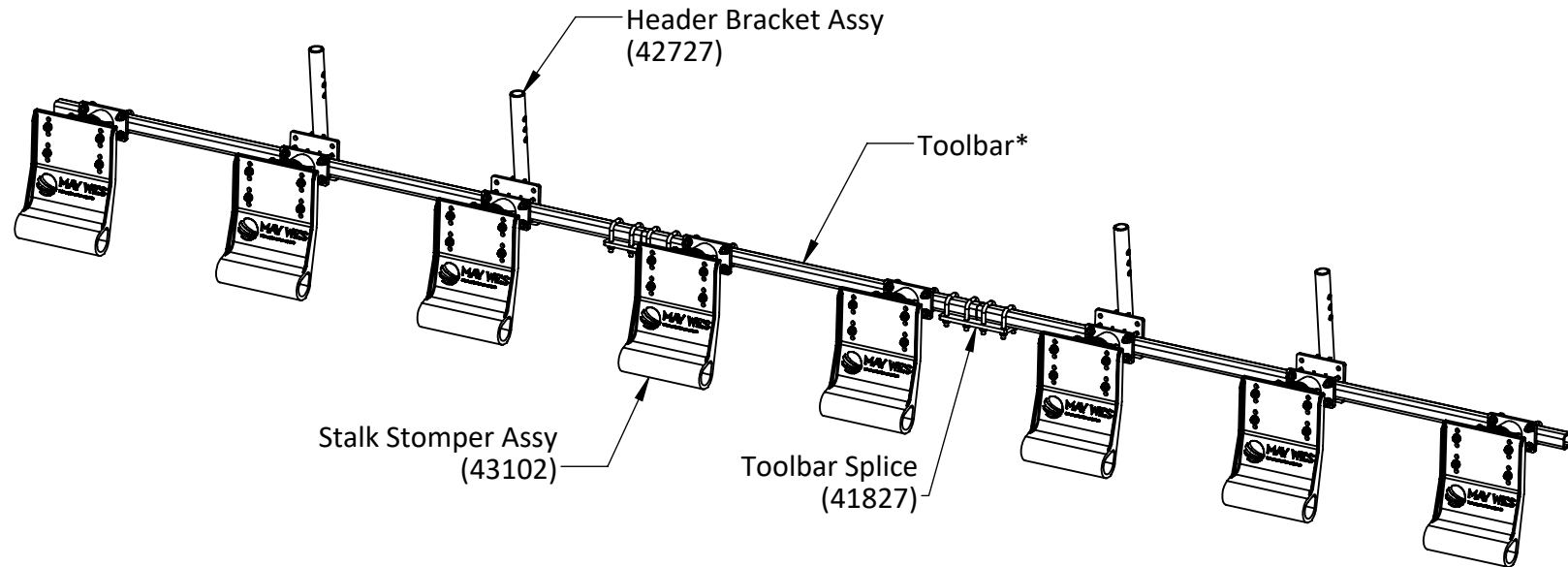

Notes:

- Illustration shown is for reference purposes only. Quantities and components will vary. Please refer to individual component part listing for specific information.
- Due to variation of implement configurations, row coverage under the feeder house may not be applicable.
- *Toolbar is not included in all kits. If a kit without Toolbar was ordered, the customer is responsible for providing required Toolbar. Toolbar may be required to be cut to length.



120 Eastgate Drive SE
Hutchinson, MN 55350

1-800-788-6483
1-320-587-2322
1-320-587-6112 (Fax)

WWW.MAYWES.COM

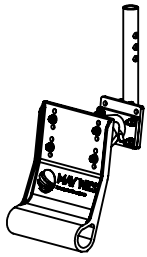

2-ROW

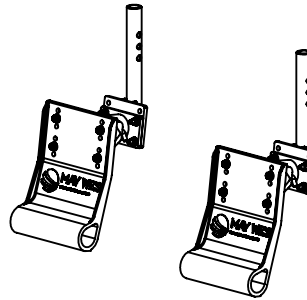
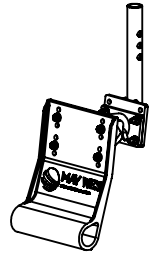

4-ROW

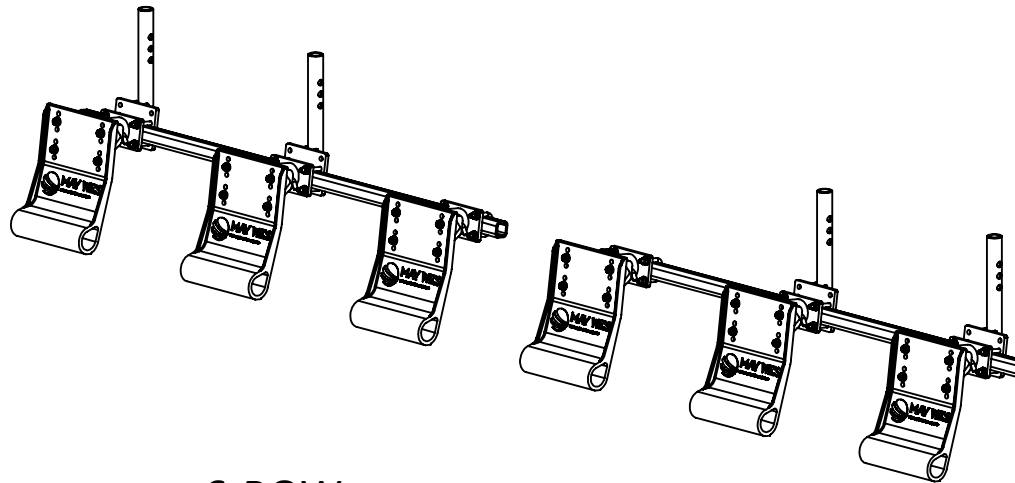
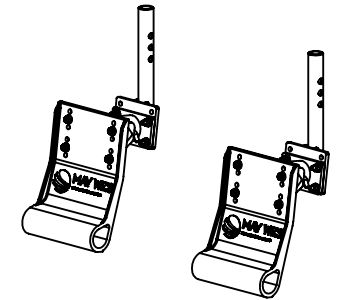

6-ROW



MAY WES
Original Poly People
A DIVISION OF PRIDE SOLUTIONS

120 Eastgate Drive SE
Hutchinson, MN 55350

1-800-788-6483
1-320-587-2322
1-320-587-6112 (Fax)

WWW.MAYWES.COM

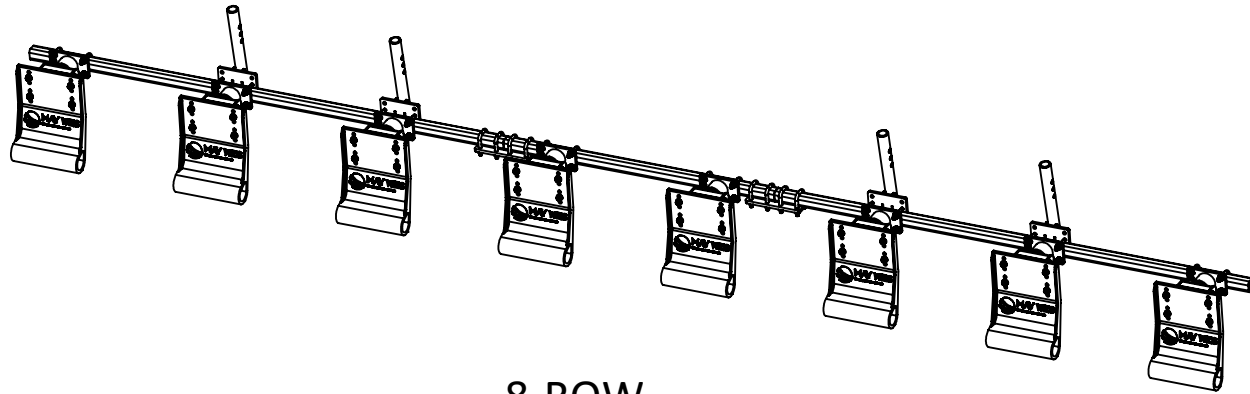

8-ROW

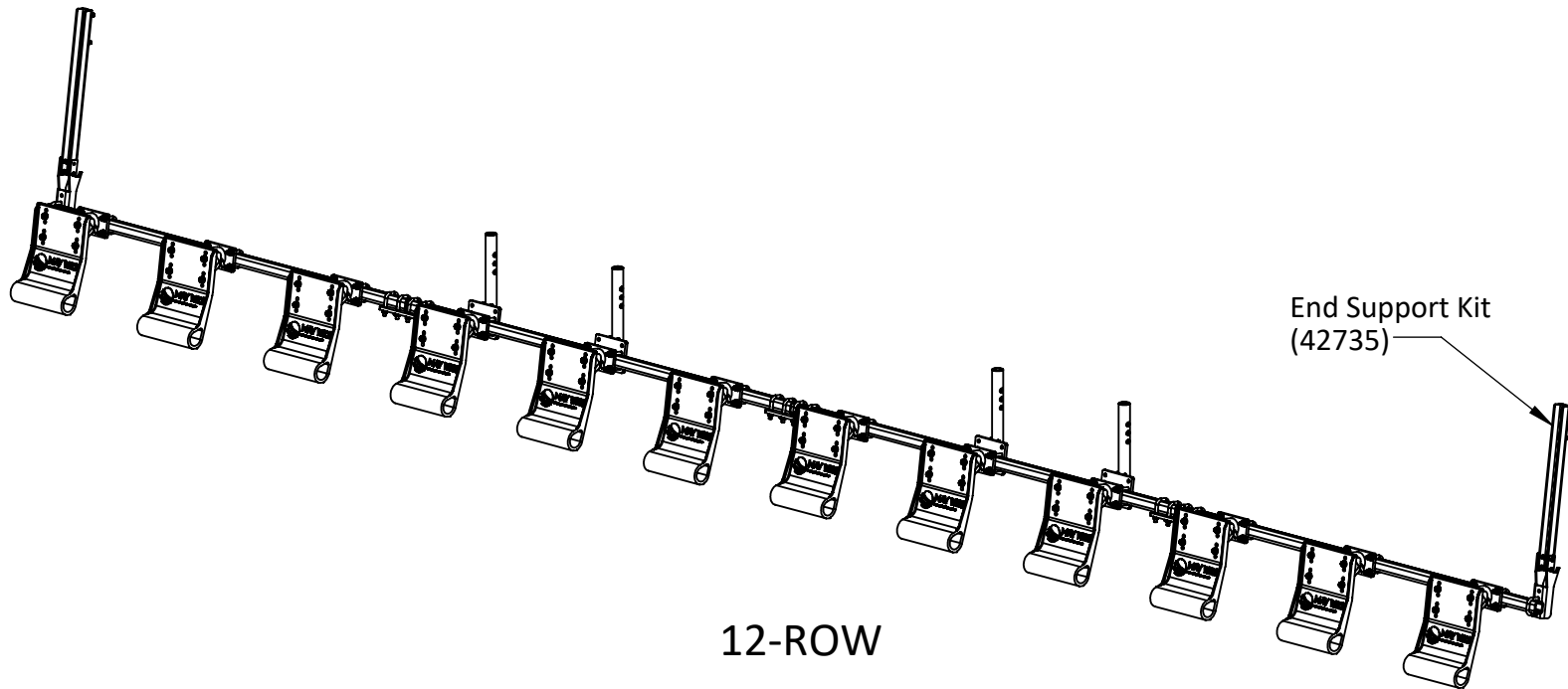

End Support Kit
(42735)

12-ROW



120 Eastgate Drive SE
Hutchinson, MN 55350

1-800-788-6483
1-320-587-2322
1-320-587-6112 (Fax)

WWW.MAYWES.COM

MACDON C SERIES HEADER BRACKET INSTALLATION

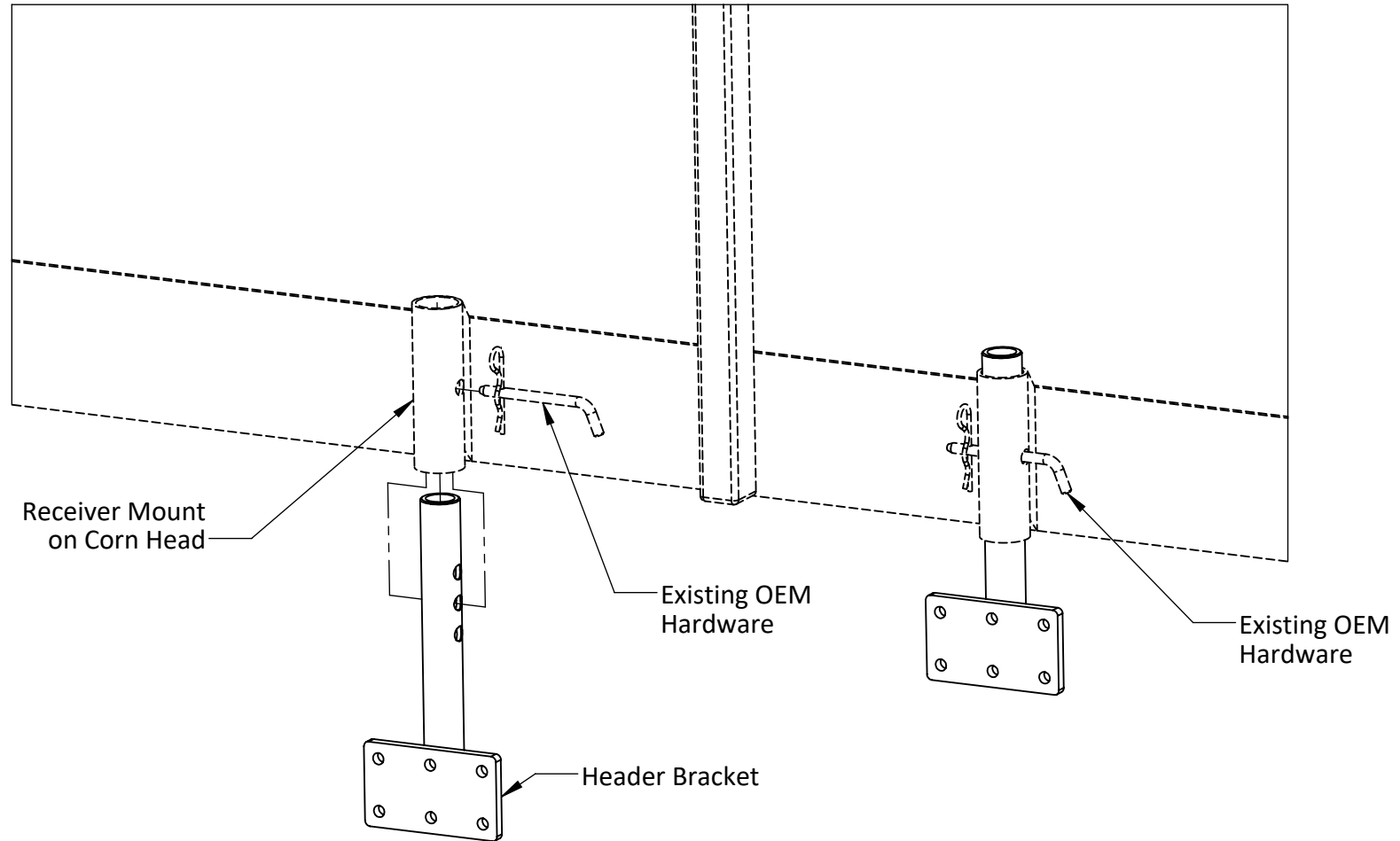

Installation Procedure:

- Park combine on level ground and lock the brakes.
- Raise the head and lock in the upright position.
- Slide Header Bracket (42727) into the existing Receiver Mounts on the head and secure in place reusing existing hardware



120 Eastgate Drive SE
Hutchinson, MN 55350

1-800-788-6483
1-320-587-2322
1-320-587-6112 (Fax)

WWW.MAYWES.COM

MACDON C SERIES STALK STOMPER OPTIONAL SETUPS

Non-Toolbar Mount Installation for 2 & 4 Row Kits

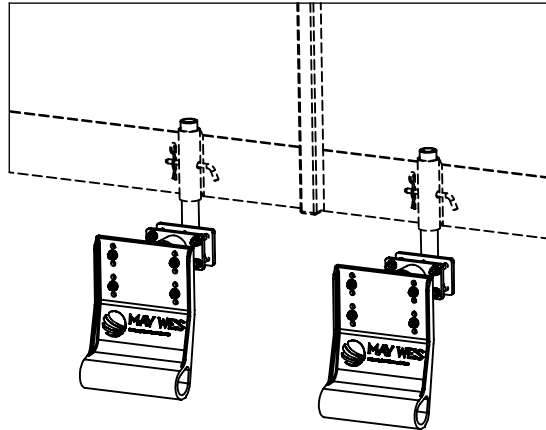

Non-Toolbar Installation Procedure:

- Fasten Mount Bracket to Header Bracket using supplied hardware.
- Install Stalk Stomper into mating features of Mount Bracket and secure with Lock Pin.

Toolbar Mount Installation for 6, 8, & 12 Row Kits

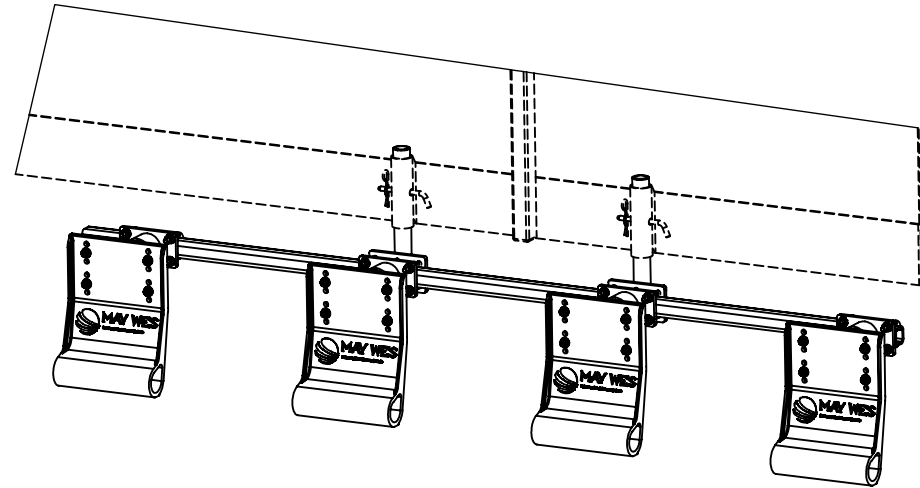

Toolbar Installation Procedure:

- Fasten Toolbar to Header Brackets using supplied bolts, Lock Washers and nuts.
- Note:** If kit was purchased with Toolbar included, Toolbar may need to be trimmed to fit.
- Fasten Mount Brackets to Toolbar using supplied U-Bolts, Lock Washers and Nuts on center of the rows to be stomped.
- Install Stalk Stomper into mating features of Mount Bracket and secure with Lock Pin.



120 Eastgate Drive SE
Hutchinson, MN 55350

1-800-788-6483
1-320-587-2322
1-320-587-6112 (Fax)

WWW.MAYWES.COM

G4 TOOLBAR MOUNT STALK STOMPER ASSEMBLY/INSTALLATION INSTRUCTIONS

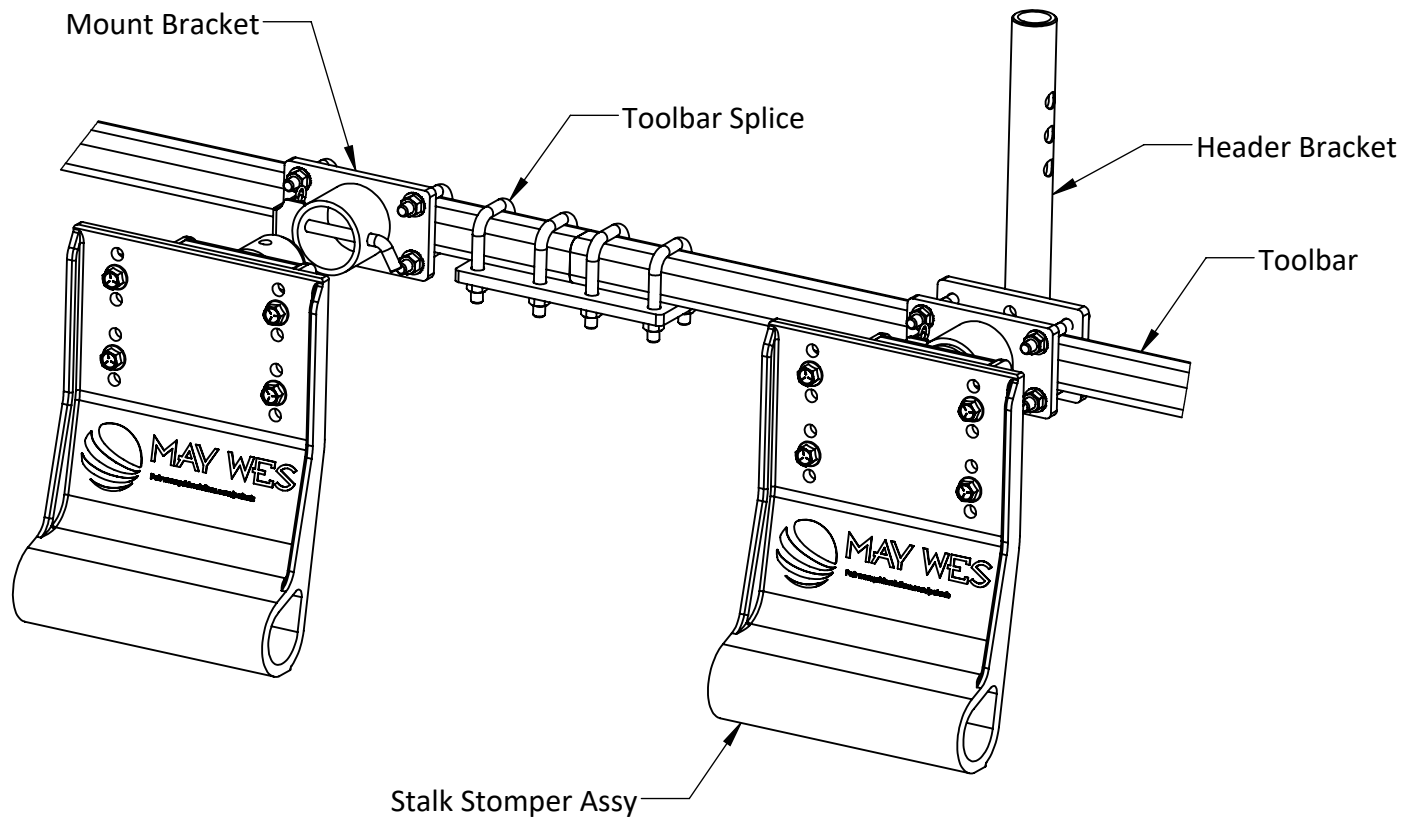

Assembly/Installation Procedure:

- Fasten Toolbar to Head Mount Brackets using supplied U-Bolts, Lock Washers and Nuts.
Note: If kit was purchased with Toolbar included, Toolbar may need to be trimmed to fit.
- Fasten Mount Brackets to Toolbar using supplied U-Bolts, Lock Washers and Nuts on center of the rows to be stomped.
- Install Stalk Stomper into mating features of Mount Bracket and secure with Lock Pin.
- **When applicable**
Fasten Toolbars together using the Toolbar Splice (not included in all kits).



120 Eastgate Drive SE
Hutchinson, MN 55350

1-800-788-6483
1-320-587-2322
1-320-587-6112 (Fax)

WWW.MAYWES.COM

MACDON C SERIES TOOLBAR MOUNT STALK STOMPER ASSEMBLY INSTRUCTIONS/PARTS LISTING

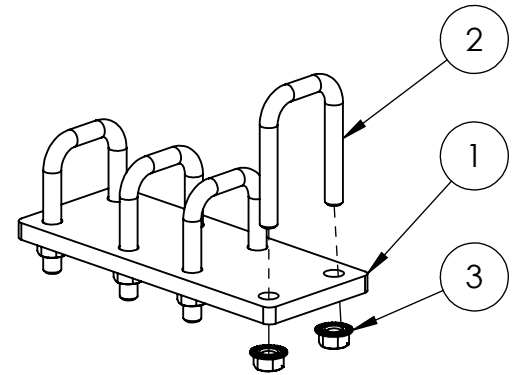
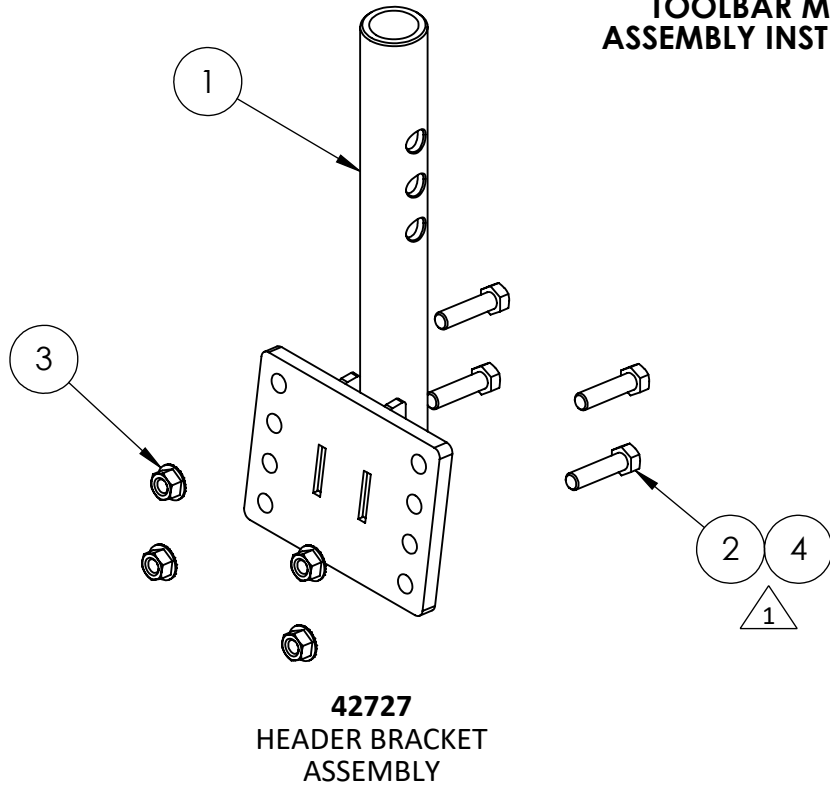

ITEM #	PART #	DESCRIPTION	QTY
1	22341	SPLICE PLATE	1
2	00986	U-BOLT 1/2"-13 X 2"	4
3	00730	NUT, 1/2"-13 HEX FLANGE	8

ITEM NO.	PART NUMBER	DESCRIPTION	QTY.
1	42727	HEAD MOUNT BRACKET	1
2	00146	BOLT, 1/2"-13 X 2 HEX	4
3	00730	NUT, 1/2"-13 HEX FLANGE	4
4	00154	BOLT, 1/2"-13 X 4" HEX	4

NOTE:

△₁ Use 2" Bolt for Non-Toolbar application and 4" Bolt for Toolbar application.

Items 9 and 10 listed below (but not shown) are not included in all kits, please order individually if needed.

ITEM #	PART #	DESCRIPTION	QTY
9	41672	72" TOOLBAR (2" X 2")	VARIABLE
10	41673	102" TOOLBAR (2" X 2")	VARIABLE



120 Eastgate Drive SE
Hutchinson, MN 55350

1-800-788-6483
1-320-587-2322
1-320-587-6112 (Fax)

WWW.MAYWES.COM