

John Deere 90 and 40 Series G4 TOOLBAR MOUNT STALK STOMPER

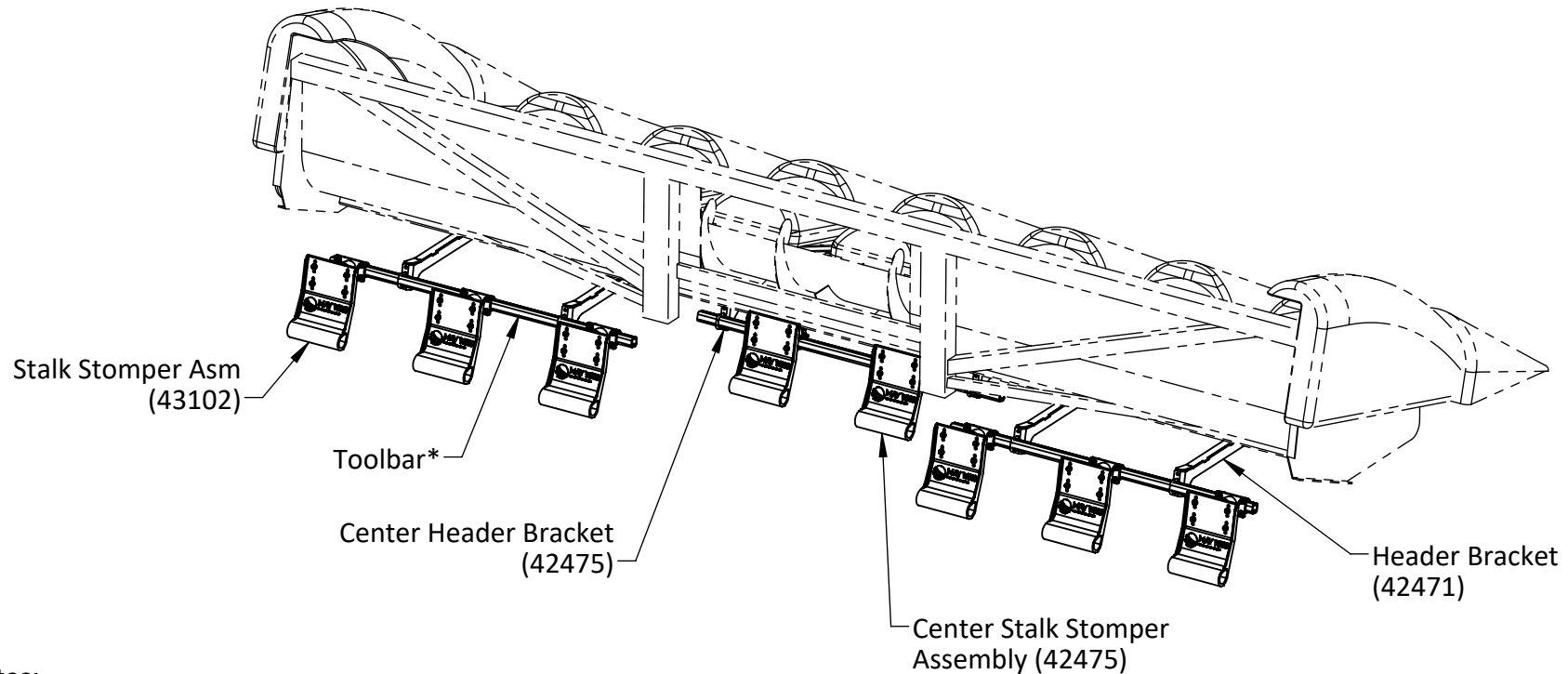

CAUTION

PLEASE REFER TO YOUR EQUIPMENT MANUFACTURER'S OPERATORS MANUAL FOR PERTINENT SAFETY PRECAUTIONS



Notes:

- Illustration shown is for reference purposes only, locations of items may vary.
Please refer to individual component parts listings for specific information.

* Square tubes, referred to as "Toolbars" are not included in all kits. If a Kit without Toolbars is ordered, the customer is responsible for providing necessary toolbars to complete the installation.



120 Eastgate Drive SE
Hutchinson, MN 55350

1-800-788-6483
1-320-587-2322
1-320-587-6112 (Fax)

WWW.MAYWES.COM

John Deere 90 and 40 Series G4 TOOLBAR MOUNT STALK STOMPER

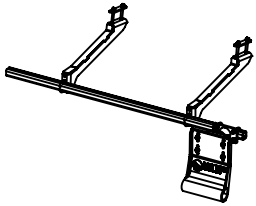

2-Row Layout

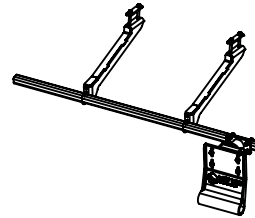
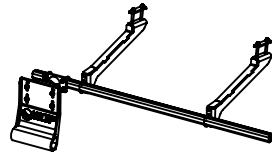

4-Row Layout

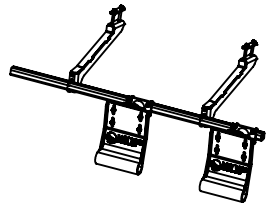
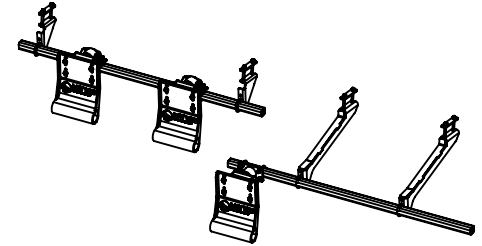

4-Row Layout

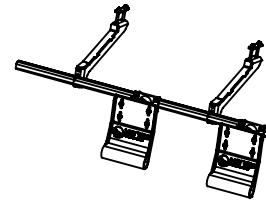
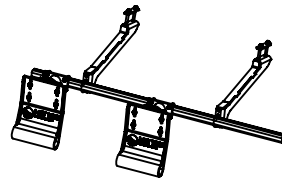

6-Row Layout

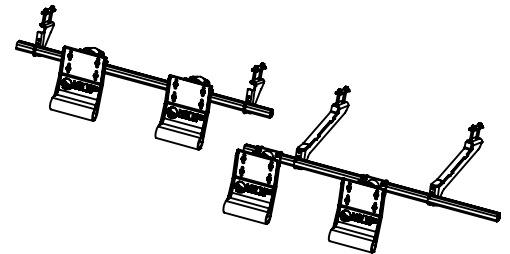

John Deere 90 and 40 Series G4 TOOLBAR MOUNT STALK STOMPER

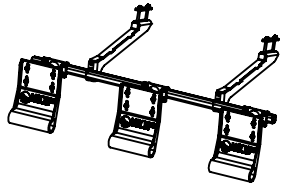

6-Row Layout

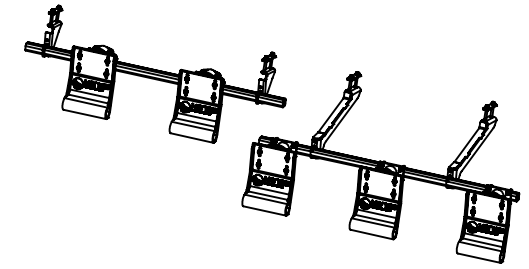
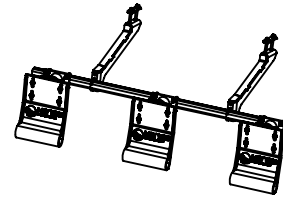
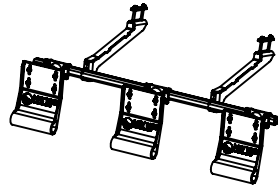

8-Row Layout

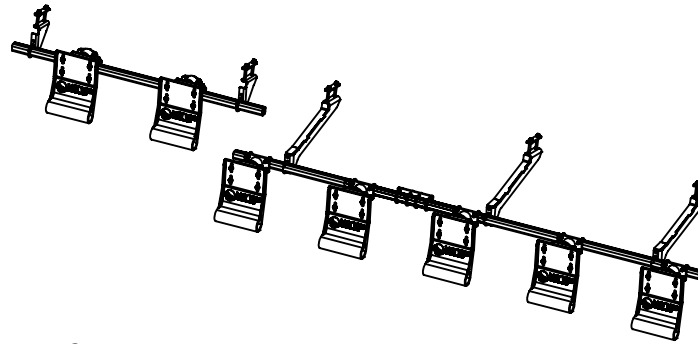
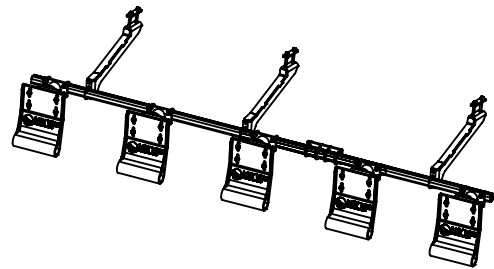

12-Row Layout



120 Eastgate Drive SE
Hutchinson, MN 55350

1-800-788-6483
1-320-587-2322
1-320-587-6112 (Fax)

WWW.MAYWES.COM

John Deere 90 and 40 Series G4 TOOLBAR MOUNT STALK STOMPER

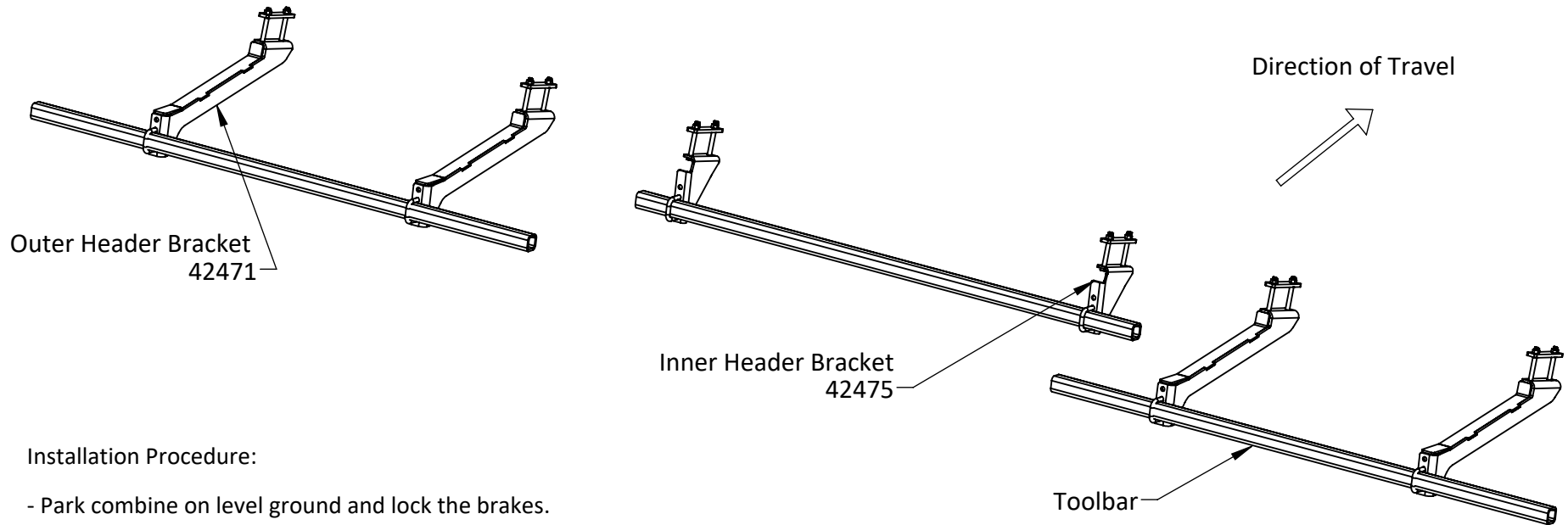

Installation Procedure:

- Park combine on level ground and lock the brakes.
- Raise the head and lock in the upright position.
- Identify the proper locations to place the header brackets. Brackets should be placed between the row units and positioned as wide as possible.
- Remove the shields that are on top of the frame tube.
- Mount the Outer Header Brackets (42471) to the bottom of the corn head frame tube. Attach by placing the strap on the top of the tube, and connecting with the bolts and nuts provided.
- Some kits come with 2 rows under the feeder house opening. These center brackets (42475) and should be placed outside of the two center row units and attached with the strap, bolts and nuts provided.
- Return the shield and fasten securely, over the strap.
- Mount toolbar (2" x 2" square tube) to the mounting brackets using the 2" U-Bolts and lock nuts provided.

Note: Toolbars come in either 72" or 102" lengths, and may need to be cut to length for your specific installation.



120 Eastgate Drive SE
Hutchinson, MN 55350

1-800-788-6483
1-320-587-2322
1-320-587-6112 (Fax)

WWW.MAYWES.COM

John Deere 90 and 40 Series G4 TOOLBAR MOUNT STALK STOMPER

Installation Procedure:

- Park combine on level ground and lock the brakes.
- Raise the head and lock in the upright position.
- Identify the proper locations to place the header brackets. Brackets should be placed between the row units and positioned as wide as possible.
- Remove the shields that are on top of the frame tube.



Shield

Fig. 1

- Mount the Outer Header Brackets (42470) to the bottom of the corn head frame tube. Attach by placing the strap (23020) on the top of the tube, and connecting with the bolts and nuts provided.



Outer Header Bracket
42470

Fig. 2

- Some kits come with 2 rows under the feeder house opening. These center brackets (22999) and should be placed outside of the two center row units and attached with the strap (23020), bolts and nuts provided.



Inner Header Bracket
42475

Fig. 3

- Return the shield and fasten securely, over the strap. (See Fig 1)
- Mount toolbar (2" x 2" square tube) to the mounting brackets using the 2" U-Bolts and lock nuts provided.



Fig. 4



Fig. 5

Note: Toolbars come in either 72" or 102" lengths, and may need to be cut to length for your specific installation.

John Deere 90 and 40 Series G4 TOOLBAR MOUNT STALK STOMPER

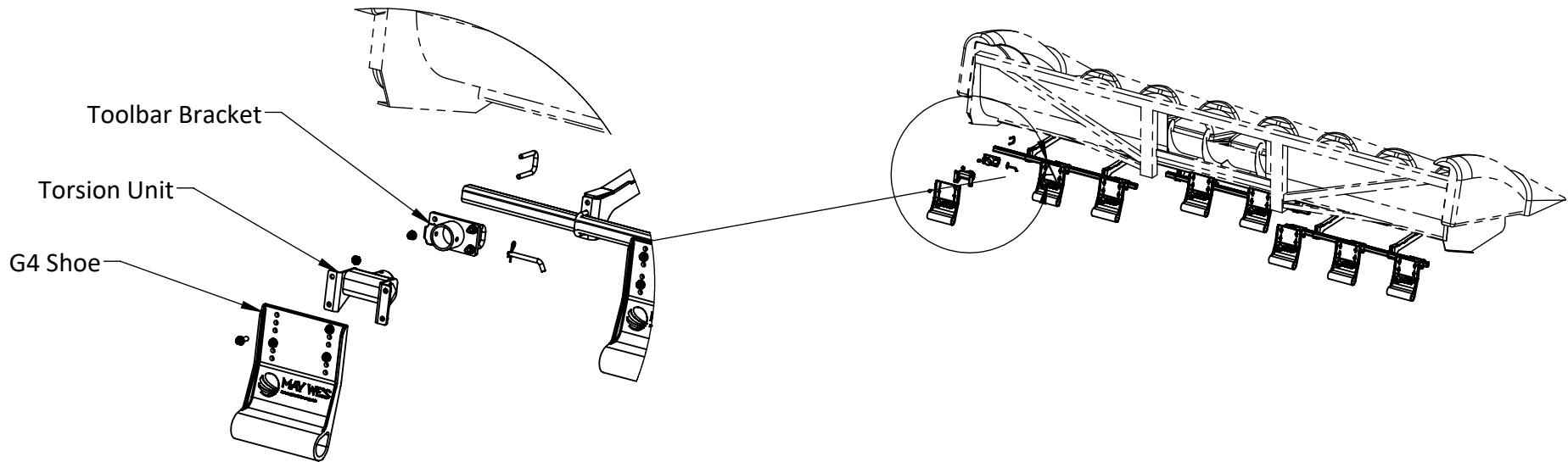

DETAIL A
SCALE 1 : 20

Installation Procedure:

- On flat ground, lower the head to approximate working height.
- Attach Toolbar Brackets using U-Bolts and nuts, behind the center of each row to be stomped.
- Lift Stalk Stomper Assembly into mating features on the mounting bracket and secure with pin and clip.
- Height can be adjusted by repositioning the shoe to the torsion unit. Each hole set will adjust the height by 1"

NOTE: Refer to G4 Stalk Stomper Instruction (Document 10274) for Setup, Operation, Maintenance, Transport and Storage Instructions



MAY WES
Original Poly People
A DIVISION OF PRIDE SOLUTIONS

120 Eastgate Drive SE
Hutchinson, MN 55350

1-800-788-6483
1-320-587-2322
1-320-587-6112 (Fax)

WWW.MAYWES.COM

**John Deere 90 and 40 Series
G4 TOOLBAR MOUNT STALK STOMPER
ASSEMBLY INSTRUCTIONS / PARTS LISTING**

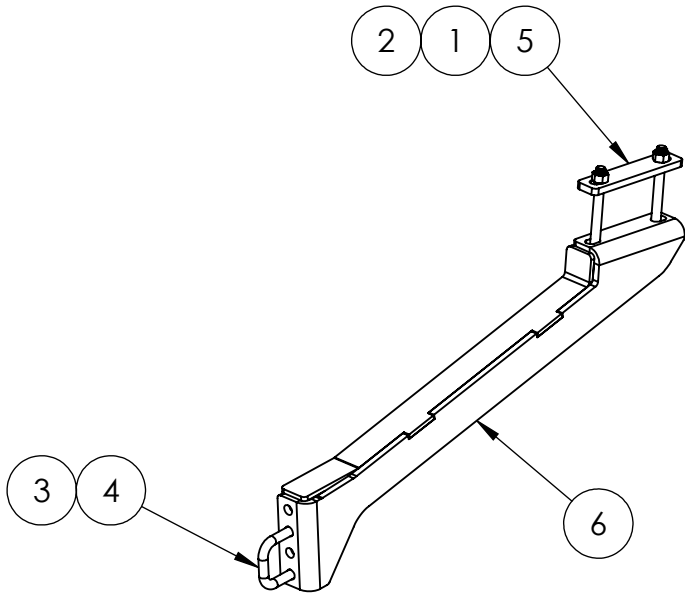

42471 - Header Bracket Assembly

ITEM #	PART #	DESCRIPTION	QTY.
1	00160	BOLT, 1/2 - 13UNC X 4-1/2"	2
2	00216	NUT, 1/2" NC TOP LOCK	2
3	00730	NUT, 1/2"-13 HEX FLANGE	2
4	00986	U-BOLT 1/2"-13 X 2"	1
5	23020	STRAP, JD 40/90 MNTG	1
6	42470	Arm, JD 90 / 40 G4 Mount	1

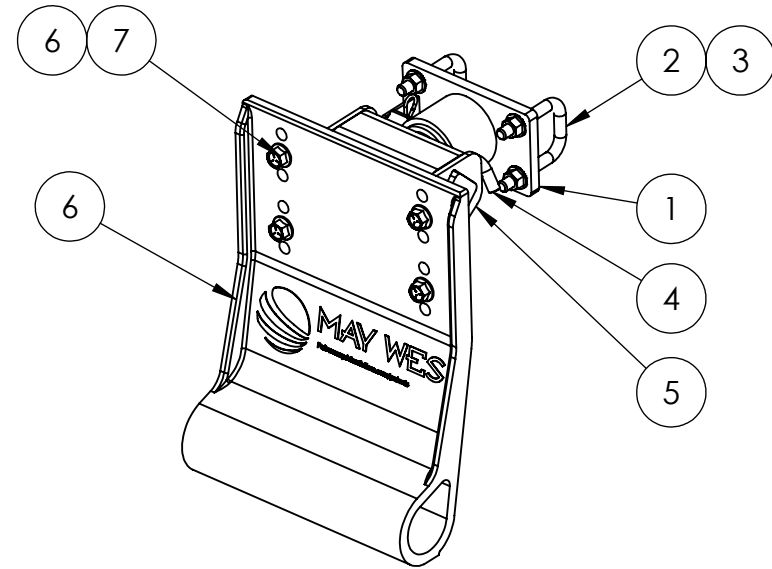

43102 - Shoe Assembly

ITEM #	PART #	DESCRIPTION	QTY.
1	42298	WLDMT; TOOLBAR MNT BRKT	1
2	00986	U-BOLT 1/2"-13 X 2"	2
3	00730	NUT, 1/2"-13 HEX FLANGE	8
4	01130	PIN, 1/2" X 4" BENT HITCH	1
5	42295	STALK STOMPER TORSION ASSY	1
6	24100	SHOE, G4 MOLDED	1
7	00729	BOLT, 1/2"-13 X 1-1/2" HEX FLANGE	4



120 Eastgate Drive SE
Hutchinson, MN 55350

1-800-788-6483
1-320-587-2322
1-320-587-6112 (Fax)

WWW.MAYWES.COM

John Deere 90 and 40 Series G4 TOOLBAR MOUNT STALK STOMPER ASSEMBLY INSTRUCTIONS / PARTS LISTING

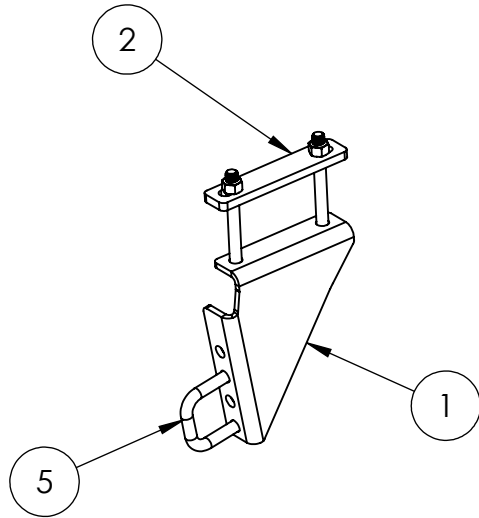

42475 - Center Header Bracket Assembly

ITEM #	PART #	DESCRIPTION	QTY.
1	22999	BRACKET, JD 90/40 G4 CENTER	1
2	23020	STRAP, JD 40/90 MNTG	1
3	00160	BOLT, 1/2 - 13UNC X 4-1/2"	2
4	00216	NUT, 1/2" NC TOP LOCK	2
5	00986	U-BOLT 1/2"-13 X 2"	1
6	00730	NUT, 1/2"-13 HEX FLANGE	2

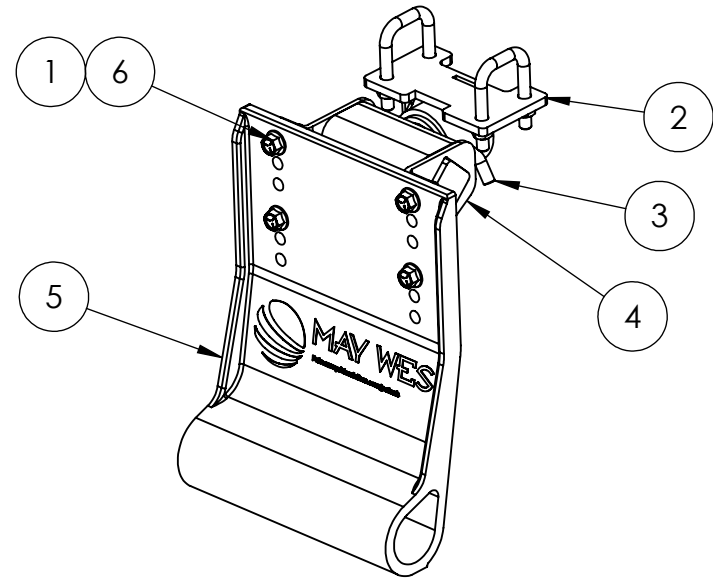

43115 - Center Shoe Assembly

ITEM #	PART #	DESCRIPTION	QTY.
1	00730	NUT, 1/2"-13 HEX FLANGE	4
2	43111	HORIZONTAL TOOLBAR BRKT ASSY	1
3	01130	PIN, 1/2" X 4" BENT HITCH	1
4	42295	STALK STOMPER TORSION ASSY	1
5	24100	SHOE, G4 MOLDED	1
6	00729	BOLT, 1/2"-13 X 1-1/2" HEX FLANGE	4



120 Eastgate Drive SE
Hutchinson, MN 55350

1-800-788-6483
1-320-587-2322
1-320-587-6112 (Fax)

WWW.MAYWES.COM