

# GERINGHOFF PATRIOT / ROTA DISC / NORTHSTAR G4 TOOLBAR MOUNT STALK STOMPER

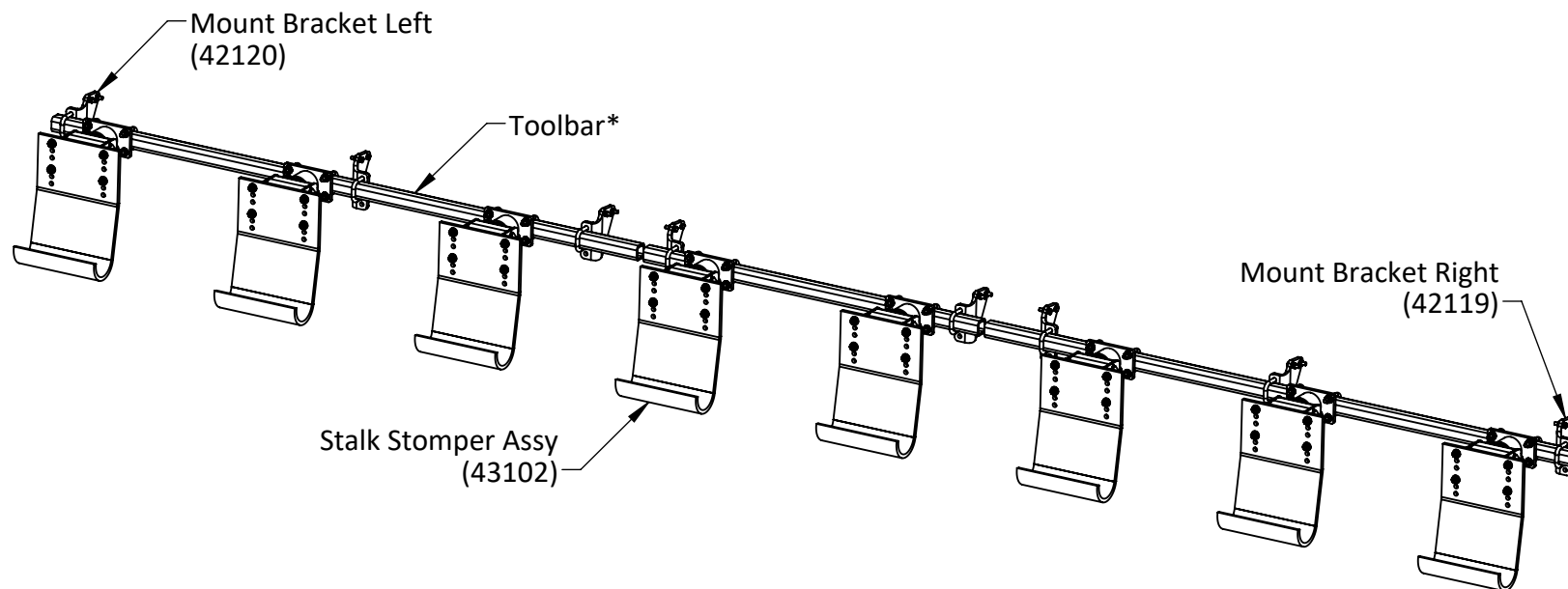

## Notes:

- Illustration shown is for reference purposes only. Quantities and components will vary. Please refer to individual component parts listings for specific information.
- \* Toolbar is not included in all kits. If a kit without Toolbar was ordered, the customer is responsible for providing required Toolbar.



**MAY WES**  
*Original Poly People*  
A DIVISION OF PRIDE SOLUTIONS

120 Eastgate Drive SE  
Hutchinson, MN 55350

1-800-788-6483  
1-320-587-2322  
1-320-587-6112 (Fax)

[WWW.MAYWES.COM](http://WWW.MAYWES.COM)

# GERINGHOFF PATRIOT / ROTA DISC / NORTHSTAR G4 TOOLBAR MOUNT STALK STOMPER ASSEMBLY/INSTALLATION INSTRUCTIONS

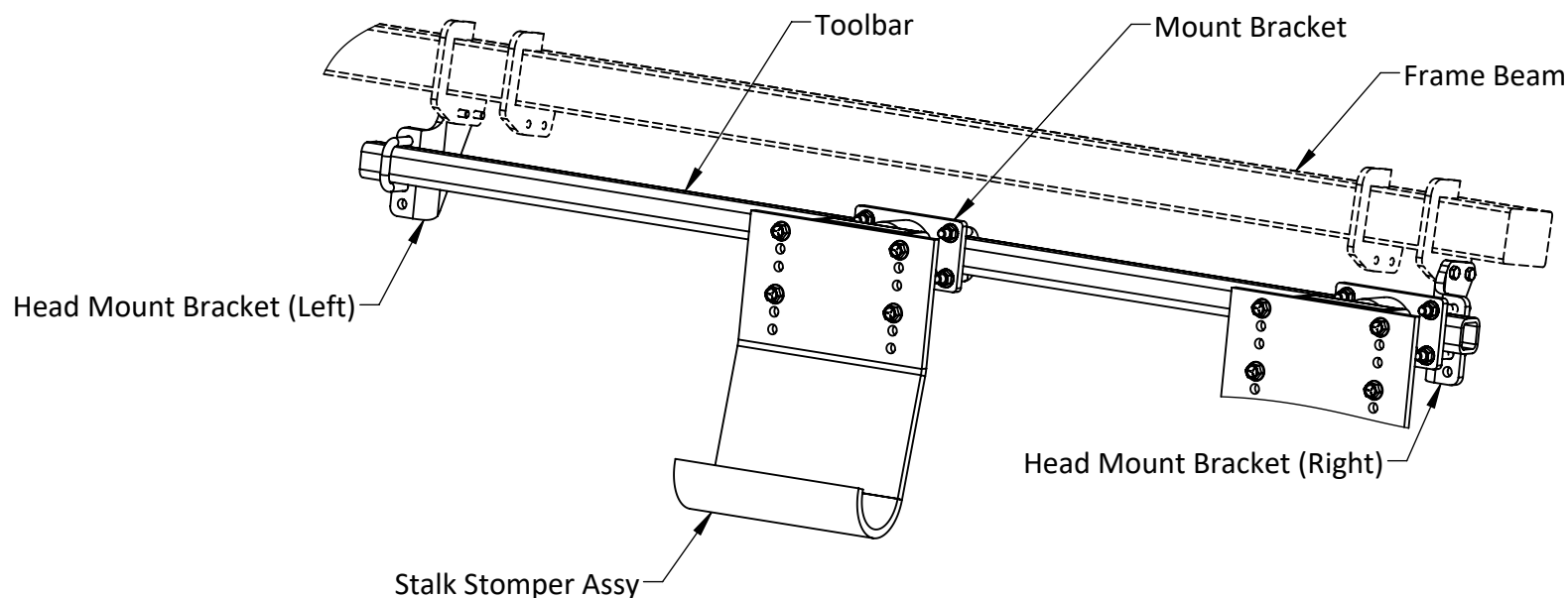

## Assembly/Installation Procedure:

- Fasten Head Mount Bracket to mating holes in head frame using supplied Bolts and Lock Nuts
- Fasten Toolbar to Head Mount Brackets using supplied U-Bolts, Lock Washers and Nuts  
**Note:** Second set of holes in Head Mount Bracket will adjust toolbar height by one inch (1")
- Fasten Mount Brackets to Toolbar using supplied U-Bolts, Lock Washers and Nuts on center of the rows to be stomped.
- Lift Stalk Stomper Assy into mating features in the Mount Bracket.  
Pull Stalk Stomper Assy back until lock pin assembly snaps into place.



**MAY WES**  
*Original Poly People*  
A DIVISION OF PRIDE SOLUTIONS

120 Eastgate Drive SE  
Hutchinson, MN 55350

1-800-788-6483  
1-320-587-2322  
1-320-587-6112 (Fax)

[WWW.MAYWES.COM](http://WWW.MAYWES.COM)

**GERINGHOFF  
PATRIOT / ROTA DISC / NORTHSTAR  
G4 TOOLBAR MOUNT STALK STOMPER  
OPTIONAL SETUPS**

**Overlapping Brackets**

If necessary, Mount Brackets and Head Mount Brackets can be overlapped to allow the Stalk Stomper Assy to be positioned on center of the row. Replace U-Bolt with 1/2"-13 x 4" Hex Bolts as shown.

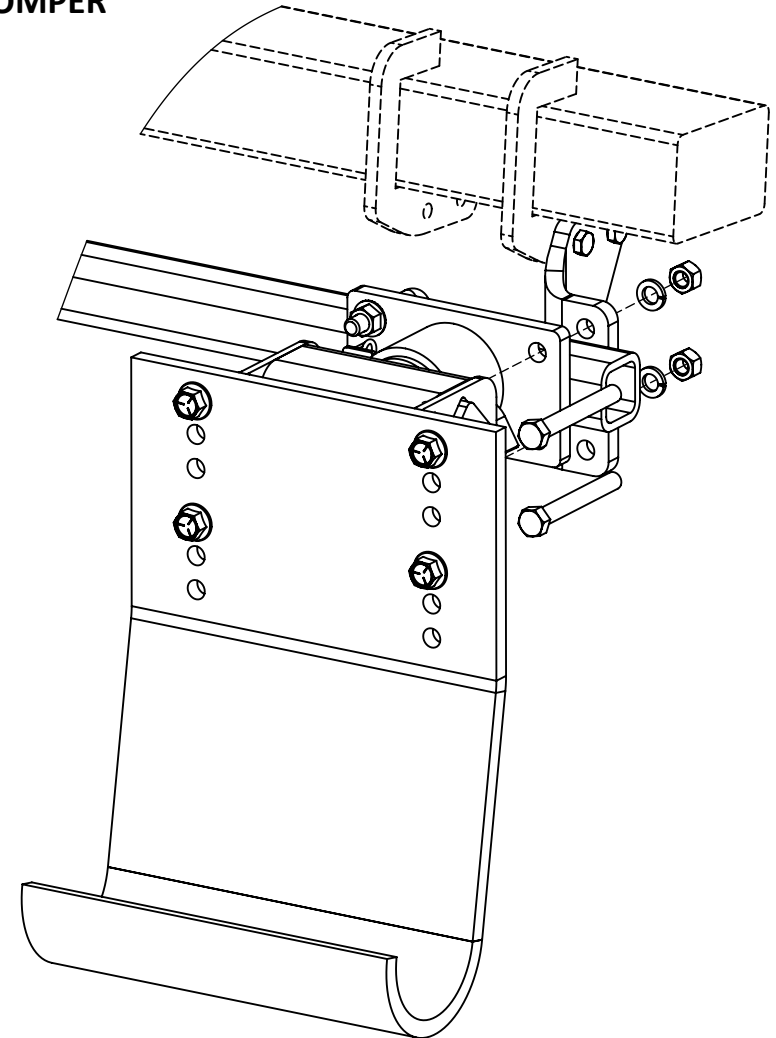

**MAY WES**  
*Original Poly People*  
A DIVISION OF PRIDE SOLUTIONS

120 Eastgate Drive SE  
Hutchinson, MN 55350

1-800-788-6483  
1-320-587-2322  
1-320-587-6112 (Fax)

[WWW.MAYWES.COM](http://WWW.MAYWES.COM)

# GERINGHOFF

## TOOLBAR MOUNT STALK STOMPER ASSEMBLY INSTRUCTIONS / PARTS LISTING

### 41827 (OPTIONAL) TOOLBAR SPLICE

**42119**  
MOUNT BRACKET RIGHT

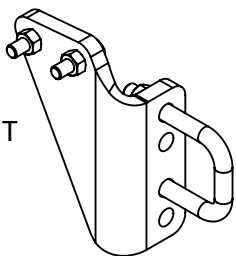

ITEM #	PART #	DESCRIPTION	QTY
1	22504	HEAD MOUNT BRACKET	1
2	00986	U-BOLT 1/2"-13	1
3	00255	WASHER, 1/2" SPRING LOCK	2
4	00214	NUT, 1/2"-13 HEX	2
5	01053	BOLT M10-1.5 X 35mm HEX	2
6	01053	NUT M10-1.5 TOPLOCK	2

**42120**  
MOUNT BRACKET LEFT

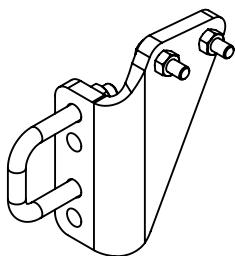

ITEM #	PART #	DESCRIPTION	QTY
1	22505	HEAD MOUNT BRACKET	1
2	00986	U-BOLT 1/2"-13	1
3	00255	WASHER, 1/2" SPRING LOCK	2
4	00214	NUT, 1/2"-13 HEX	2
5	01053	BOLT M10-1.5 X 35mm HEX	2
6	01053	NUT M10-1.5 TOPLOCK	2

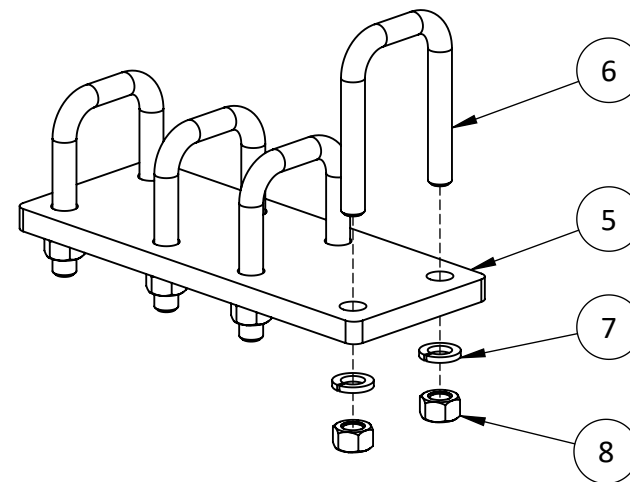

ITEM #	PART #	DESCRIPTION	QTY
5	22341	SPLICE PLATE	1
6	00986	U-BOLT 1/2"-13	4
7	00255	WASHER, 1/2" SPRING LOCK	8
8	00214	NUT, 1/2"-13 HEX	8

**Items 9 and 10 listed below (but not shown) are not included in all kits, please order individually if needed.**

ITEM #	PART #	DESCRIPTION	QTY
9	41672	72" TOOLBAR (2" X 2")	VARIES
10	41673	102" TOOLBAR (2" X 2")	VARIES



**MAY WES**  
*Original Poly People*  
A DIVISION OF PRIDE SOLUTIONS

120 Eastgate Drive SE  
Hutchinson, MN 55350

1-800-788-6483  
1-320-587-2322  
1-320-587-6112 (Fax)

[WWW.MAYWES.COM](http://WWW.MAYWES.COM)

**43102**  
**G4 TOOLBAR MOUNT**  
**STALK STOMPER ASSEMBLY**

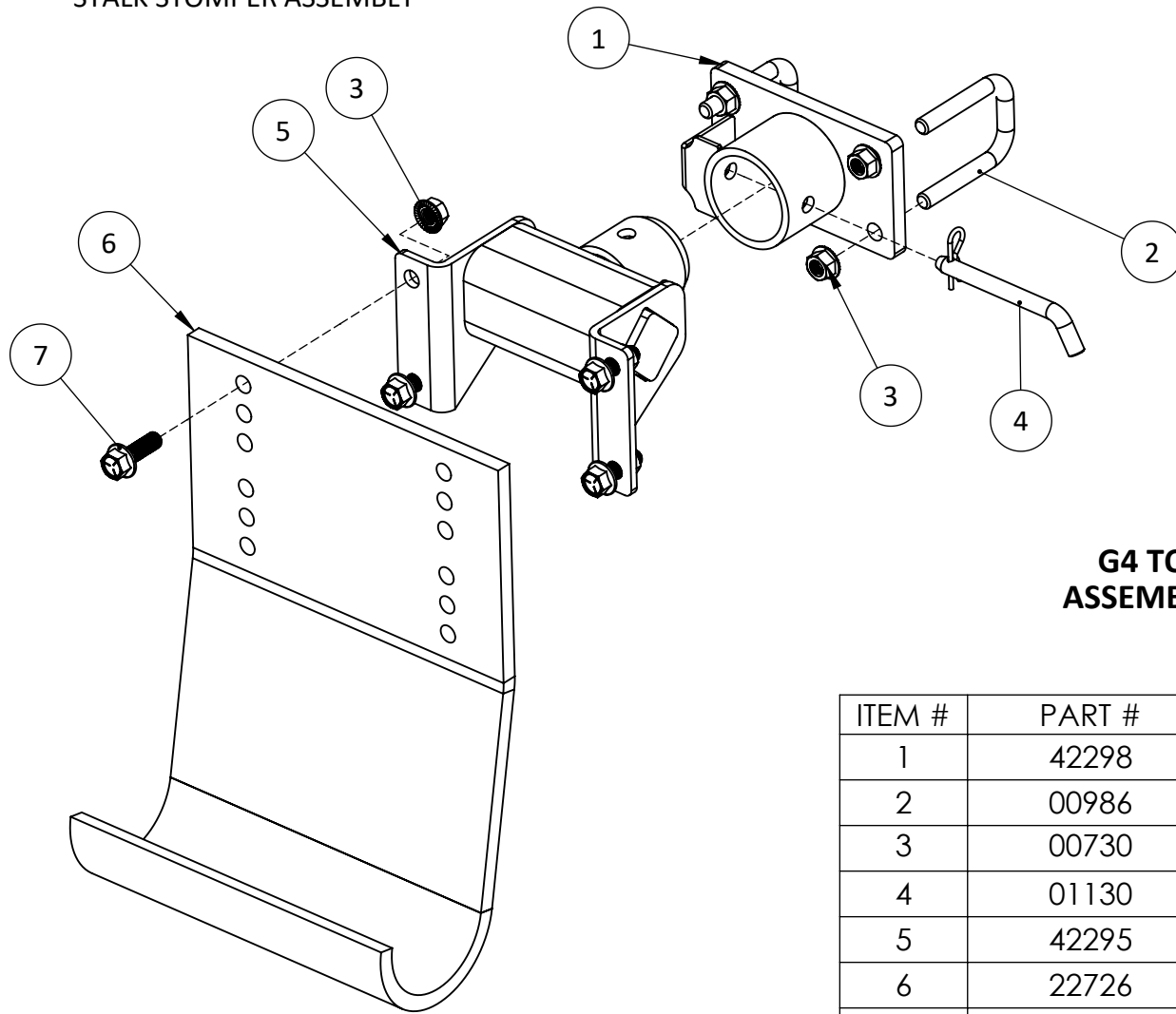

**G4 TOOLBAR MOUNT STALK STOMPER**  
**ASSEMBLY INSTRUCTIONS / PARTS LISTING**

ITEM #	PART #	DESCRIPTION	QTY.
1	42298	WLDMT; TOOLBAR MNT BRKT	1
2	00986	U-BOLT 1/2"-13	2
3	00730	Nut 1/2"-13 Serrated Flange	8
4	01130	PIN, 1/2" X 4" BENT HITCH	1
5	42295	STALK STOMPER TORSION ASSY	1
6	22726	POLY SHOE	1
7	00729	Bolt 1/2-13 X 1-1/2 Flange Head	4



120 Eastgate Drive SE  
 Hutchinson, MN 55350

1-800-788-6483  
 1-320-587-2322  
 1-320-587-6112 (Fax)

WWW.MAYWES.COM