

# DRAGO

## 12 ROW FOLDING HEAD

### G4 TOOLBAR MOUNT STALK STOMPER

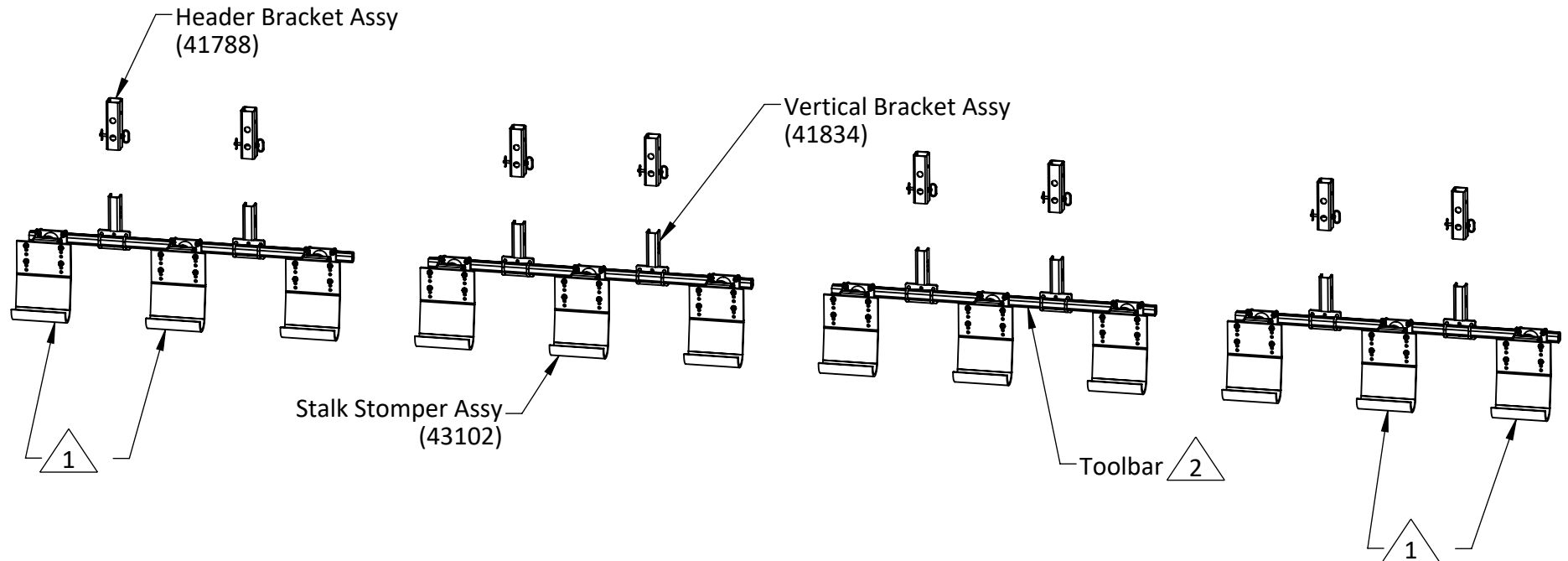

#### Notes:

- 1** Prior to folding head, remove rows 1, 2, 11, & 12. This will provide clearance in front of cab when head is in folded position.
- 2** Toolbar is not included in all kits. If a kit without Toolbar was ordered, the customer is responsible for providing required Toolbar.
3. Illustration shown is for reference purposes only. Quantities and components will vary. Please refer to individual component parts listings for specific information.



120 Eastgate Drive SE  
Hutchinson, MN 55350

1-800-788-6483  
1-320-587-2322  
1-320-587-6112 (Fax)

[WWW.MAYWES.COM](http://WWW.MAYWES.COM)

## DRAGO 12 ROW FOLDING HEAD HEADER BRACKET INSTALLATION

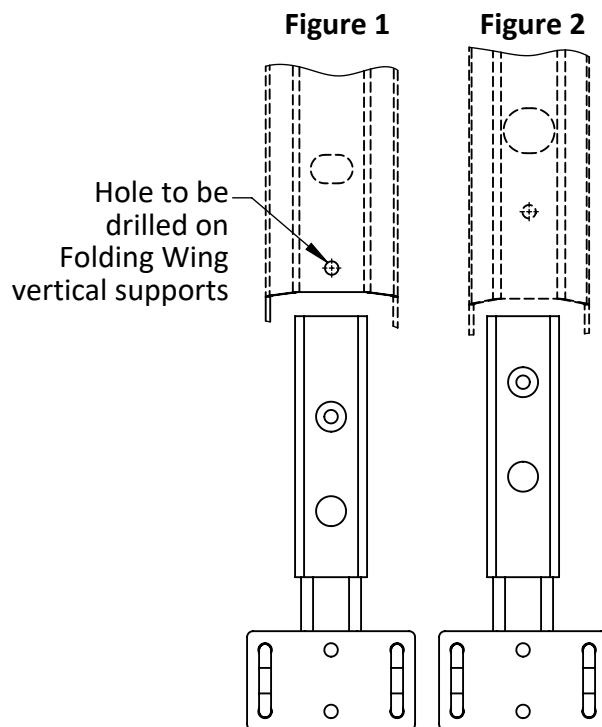
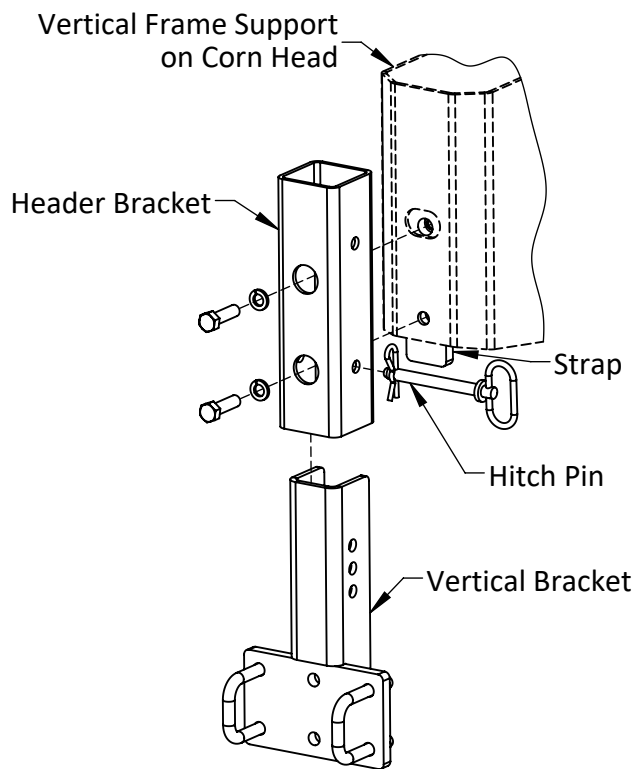

### Installation Procedure:

- Park combine on level ground and lock the brakes.
- Raise the head and lock in the upright position.
- On the folding wings, drill a  $\varnothing 9/16$  clearance hole below the existing opening on the vertical frame supports (see Figure 1).
- Mount the Header Brackets to the vertical frame supports on the rear of the corn head using the straps, washers and bolts supplied. Slide the Strap up into the opening on the bottom of the hollow frame support. Using the existing hole pattern as clearance for the bolts, fasten the Header Bracket to the frame support "sandwiching" the frame support wall between the Header Bracket and Strap.
- Note:** Drago heads have multiple hole patterns used for mounting the Header Brackets (see hole patterns #1 & #2 above).
- Heads commonly will have hole pattern #1, with some heads having a combination of holes #1 & #2.
- If the header has a combination of holes #1 & #2, Header Brackets are designed to position the Vertical Brackets in line with each other (see above).
- If header has hole pattern #1, the Header Bracket can be "flipped" to allow for more height adjustability for down pressure on Stalk Stomper.
- Install Vertical Brackets into Header Brackets and secure in place with Hitch Pins.
- Refer to the Toolbar Mount Stalk Stomper Instructions to continue installation.



120 Eastgate Drive SE  
PO Box 7  
Hutchinson, MN 55350

1-800-788-6483  
1-320-587-2322  
1-320-587-6112 (Fax)

WWW.MAYWES.COM

# DRAGO

## TOOLBAR MOUNT STALK STOMPER ASSEMBLY INSTRUCTIONS / PARTS LISTING

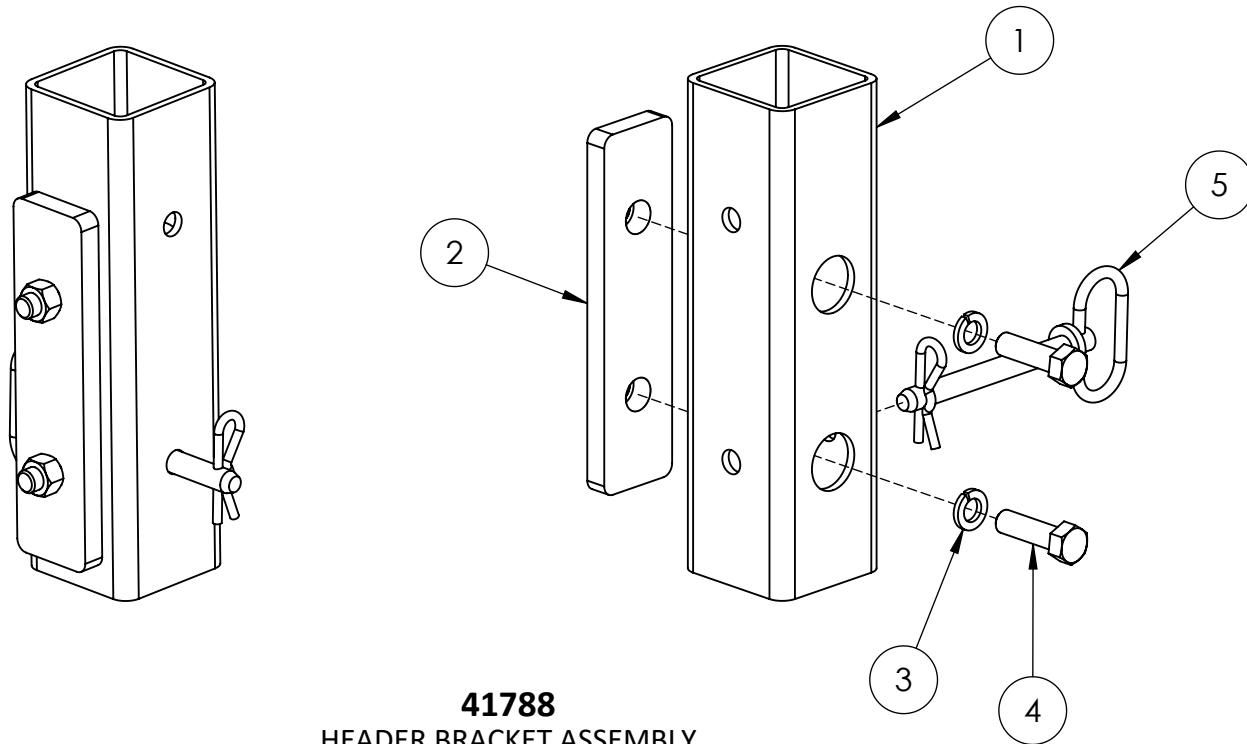

**41788**  
HEADER BRACKET ASSEMBLY

ITEM #	PART #	DESCRIPTION	QTY
1	22240	RECEIVER BODY	1
2	41789	MOUNT STRAP	1
3	00255	WASHER, 1/2" SPRING LOCK	2
4	00139	BOLT, 1/2"-13 X 1-3/4" HEX	2
5	20433	HITCH PIN	1