

DRAGO GT G4 TOOLBAR MOUNT STALK STOMPER

CAUTION

PLEASE REFER TO YOUR EQUIPMENT MANUFACTURER'S OPERATORS MANUAL FOR PERTINENT SAFETY PRECAUTIONS

IMPORTANT

Read all instructions before starting installation

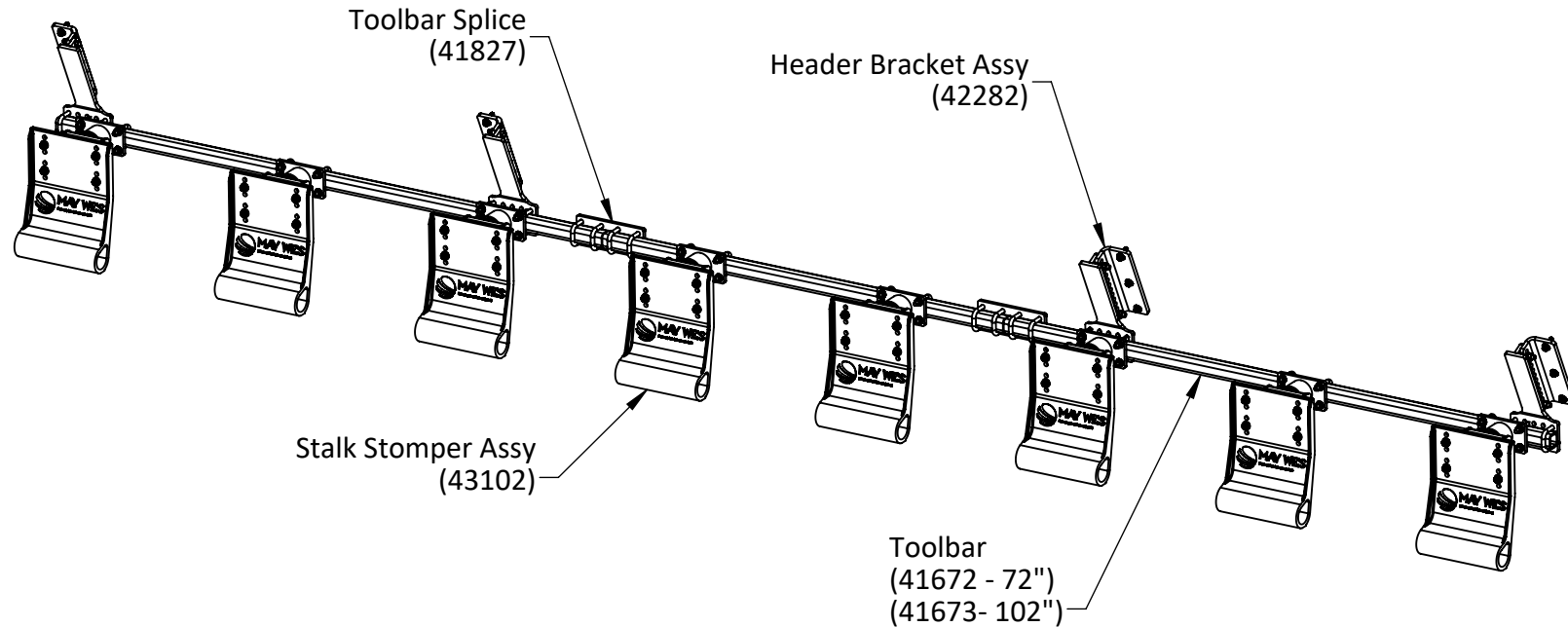

Notes:

- Illustration shown is for reference purposes only. Quantities and components will vary. Please refer to individual component parts listings for specific information.
- Due to variation of implement configurations, row coverage under the feeder house may not be applicable.
- * Toolbar is not included in all kits. If a kit without Toolbar was ordered, the customer is responsible for providing required Toolbar.



MAY WES
Original Poly People
A DIVISION OF PRIDE SOLUTIONS

120 Eastgate Drive SE
Hutchinson, MN 55350

1-800-788-6483
1-320-587-2322
1-320-587-6112 (Fax)

WWW.MAYWES.COM

DRAGO GT G4 TOOLBAR MOUNT STALK STOMPER

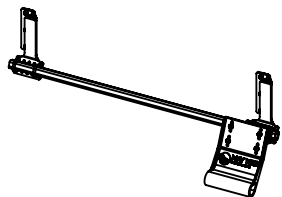

2-Row Layout

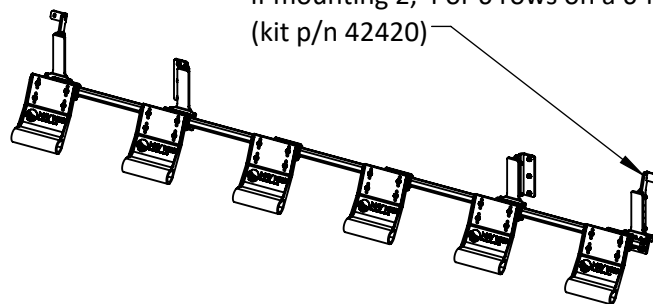

6-Row Layout
(6-Row Head)

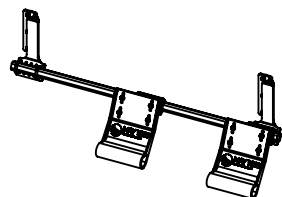

4-Row Layout

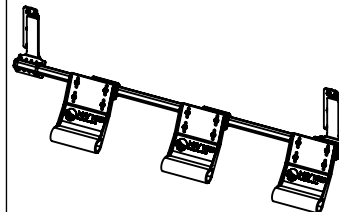
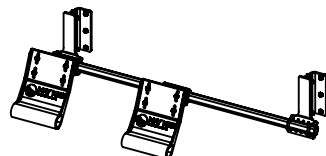

6-Row Layout
(8-Row Head & Larger)

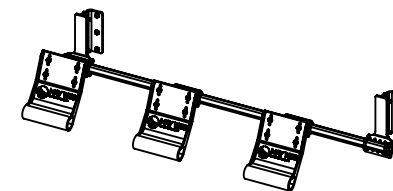

*Due to variation of implement configurations, installation may vary



MAY WES
Original Poly People
A DIVISION OF PRIDE SOLUTIONS

120 Eastgate Drive SE
Hutchinson, MN 55350

1-800-788-6483
1-320-587-2322
1-320-587-6112 (Fax)

WWW.MAYWES.COM

DRAGO GT G4 TOOLBAR MOUNT STALK STOMPER

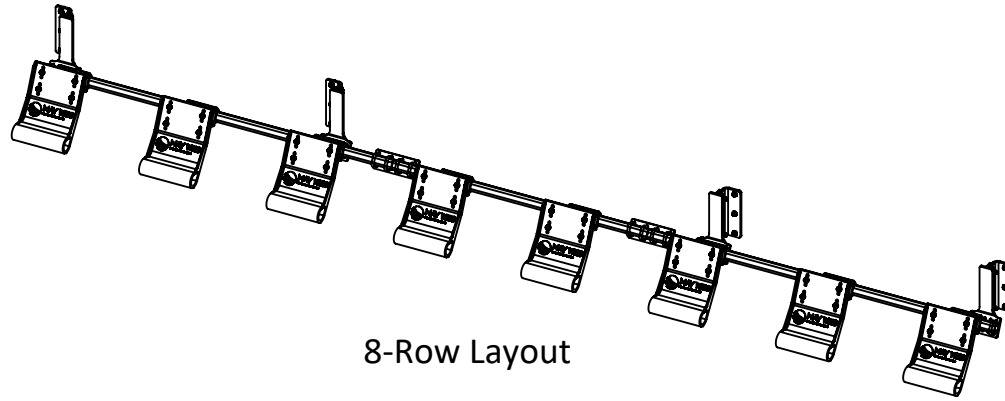

8-Row Layout

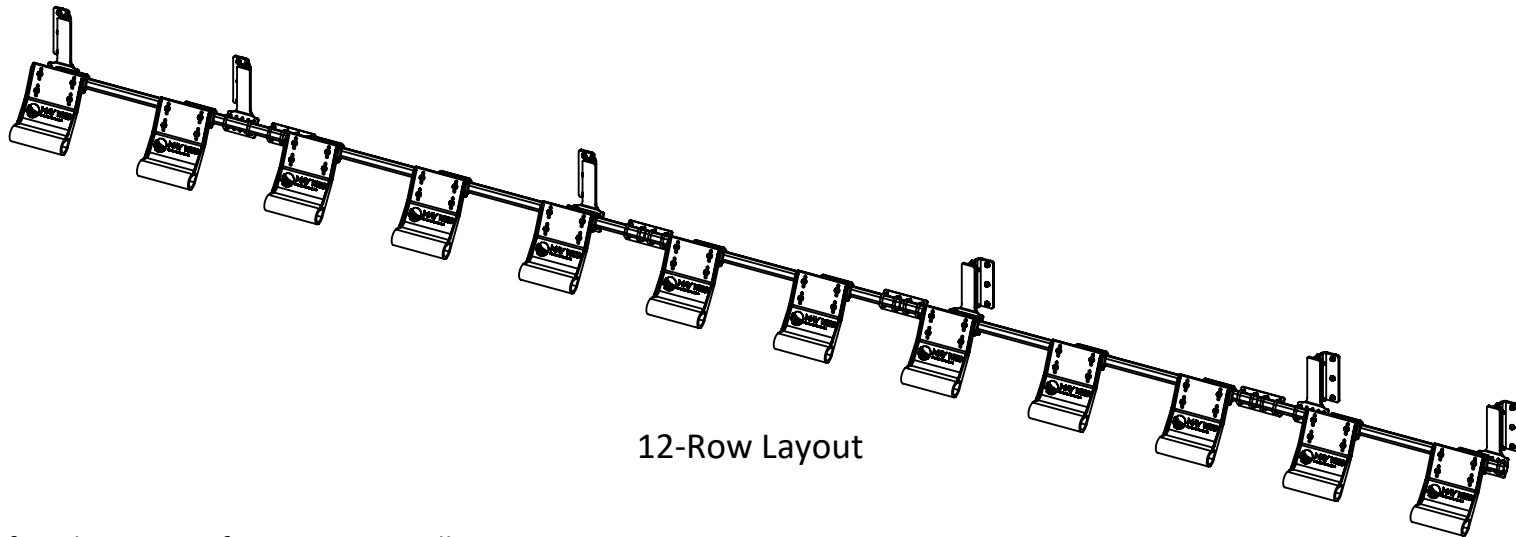

12-Row Layout

*Due to variation of implement configurations, installation may vary



MAY WES
Original Poly People
A DIVISION OF PRIDE SOLUTIONS

120 Eastgate Drive SE
Hutchinson, MN 55350

1-800-788-6483
1-320-587-2322
1-320-587-6112 (Fax)

WWW.MAYWES.COM

DRAGO GT G4 TOOLBAR MOUNT STALK STOMPER

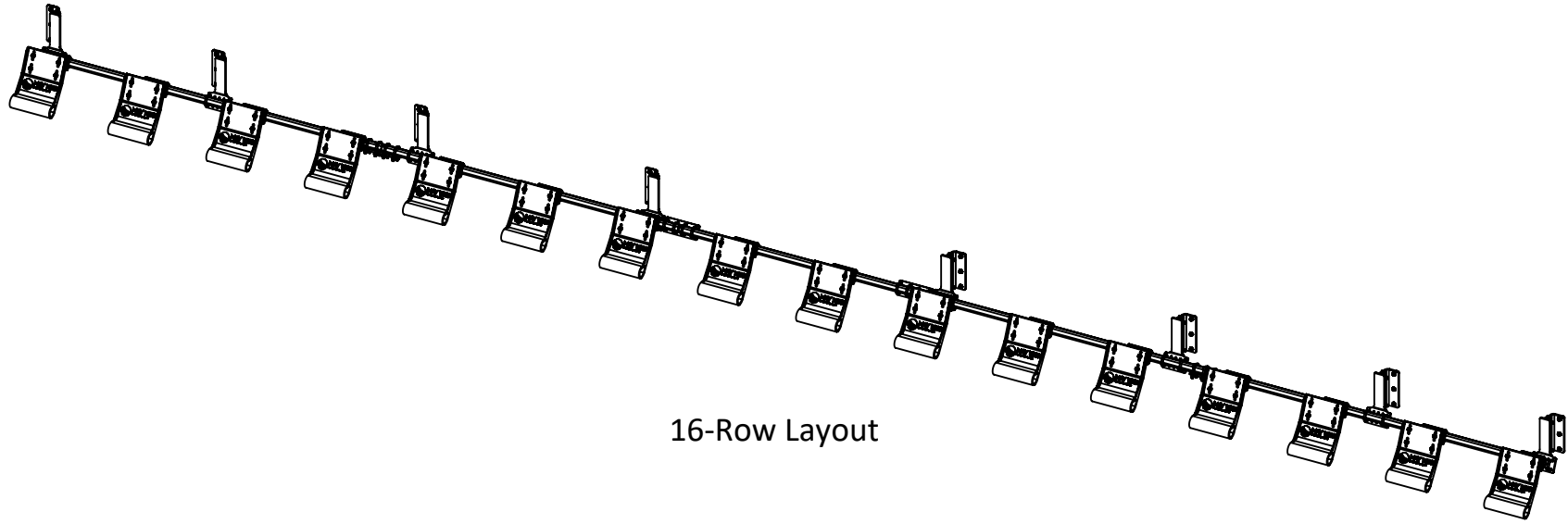

16-Row Layout

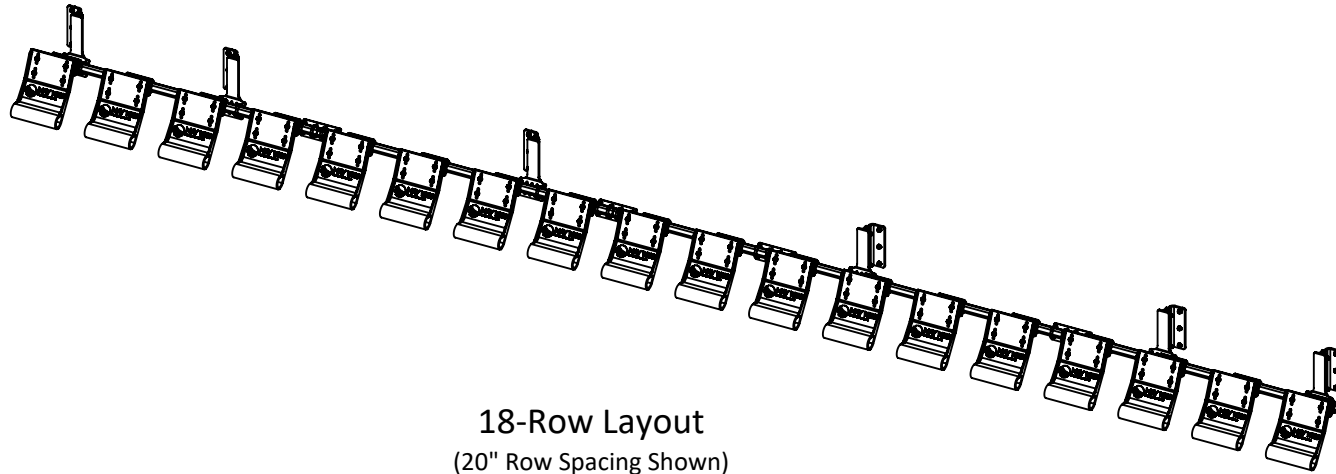

18-Row Layout
(20" Row Spacing Shown)

*Due to variation of implement configurations, installation may vary



MAY WES
Original Poly People
A DIVISION OF PRIDE SOLUTIONS

120 Eastgate Drive SE
Hutchinson, MN 55350

1-800-788-6483
1-320-587-2322
1-320-587-6112 (Fax)

WWW.MAYWES.COM

DRAGO GT HEADER BRACKET INSTALLATION



Figure 1



Figure 2



Figure 3

Installation Procedure:

- Park combine on level ground and lock the brakes.
- Raise the head and lock in the upright position.
- Mount the Header Brackets to the vertical frame supports (figure 1) on the rear of the corn head using the M12 Hex Flange bolts supplied (figure 2)
- Install Vertical Brackets onto Header Brackets and secure in place with supplied bolts, washers, and nuts (figure 3)
- Refer to the Toolbar Mount Stalk Stomper Instructions to continue installation.



120 Eastgate Drive SE
Hutchinson, MN 55350

1-800-788-6483
1-320-587-2322
1-320-587-6112 (Fax)

WWW.MAYWES.COM

DRAGO GT 6-ROW HEAD END HEADER BRACKET INSTALL

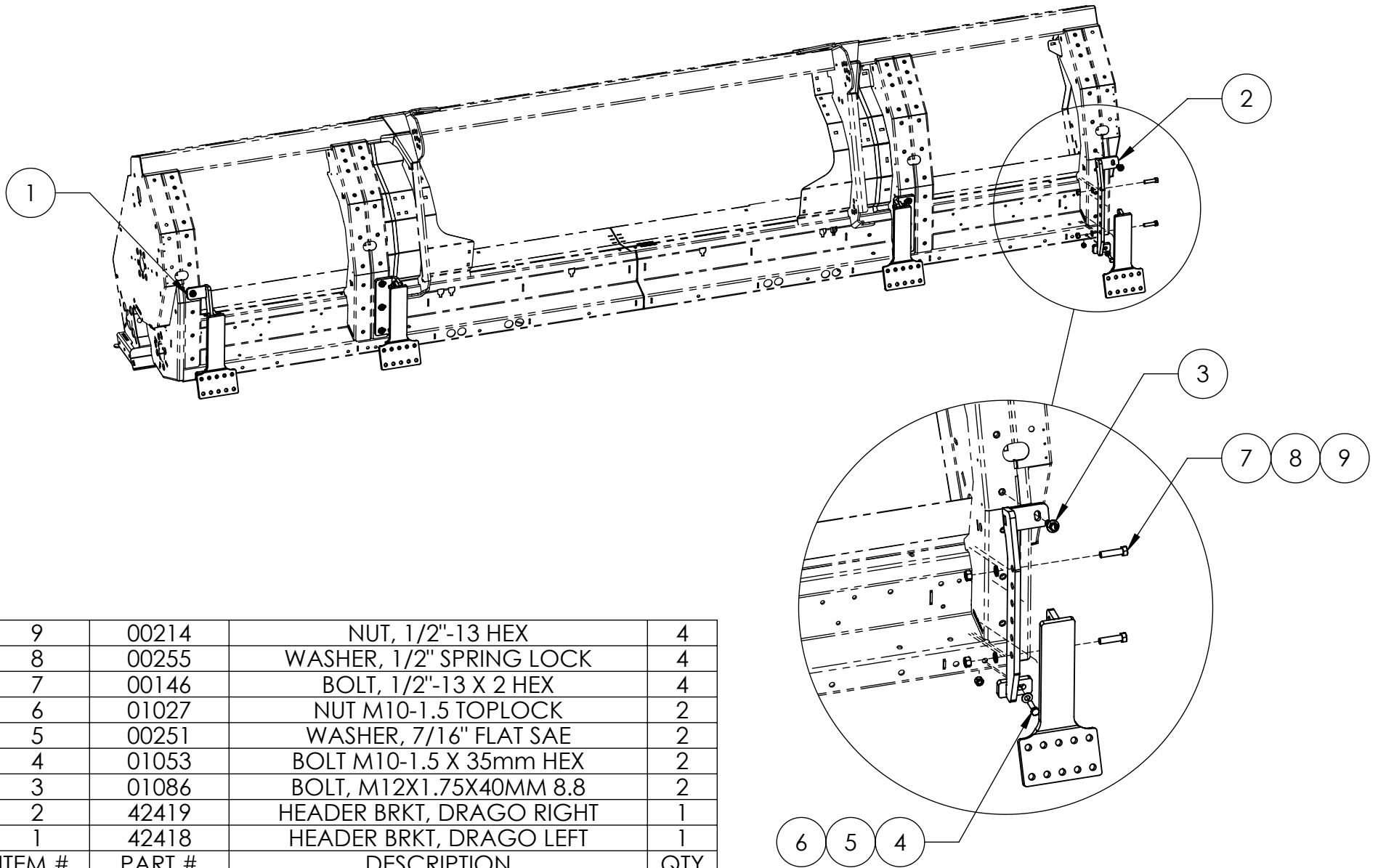

9	00214	NUT, 1/2"-13 HEX	4
8	00255	WASHER, 1/2" SPRING LOCK	4
7	00146	BOLT, 1/2"-13 X 2 HEX	4
6	01027	NUT M10-1.5 TOPLOCK	2
5	00251	WASHER, 7/16" FLAT SAE	2
4	01053	BOLT M10-1.5 X 35mm HEX	2
3	01086	BOLT, M12X1.75X40MM 8.8	2
2	42419	HEADER BRKT, DRAGO RIGHT	1
1	42418	HEADER BRKT, DRAGO LEFT	1
ITEM #	PART #	DESCRIPTION	QTY



MAY WES
Original Poly People
A DIVISION OF PRIDE SOLUTIONS

120 Eastgate Drive SE
Hutchinson, MN 55350

1-800-788-6483
1-320-587-2322
1-320-587-6112 (Fax)

WWW.MAYWES.COM

DRAGO GT TOOLBAR MOUNT STALK STOMPER ASSEMBLY INSTRUCTIONS / PARTS LISTING

ITEM #	PART #	DESCRIPTION	QTY.
1	22702	MOUNT BRACKET	1
2	42284	VERTICAL BRACKET	1
3	00986	U-BOLT 1/2"-13 X 2"	2
4	00730	NUT, 1/2"-13 HEX FLANGE	4
5	00146	BOLT, 1/2"-13 X 2 HEX	2
6	00255	WASHER, 1/2" SPRING LOCK	2
7	00214	NUT, 1/2"-13 HEX	2
8	01086	BOLT, M12X1.75X40MM 8.8	3

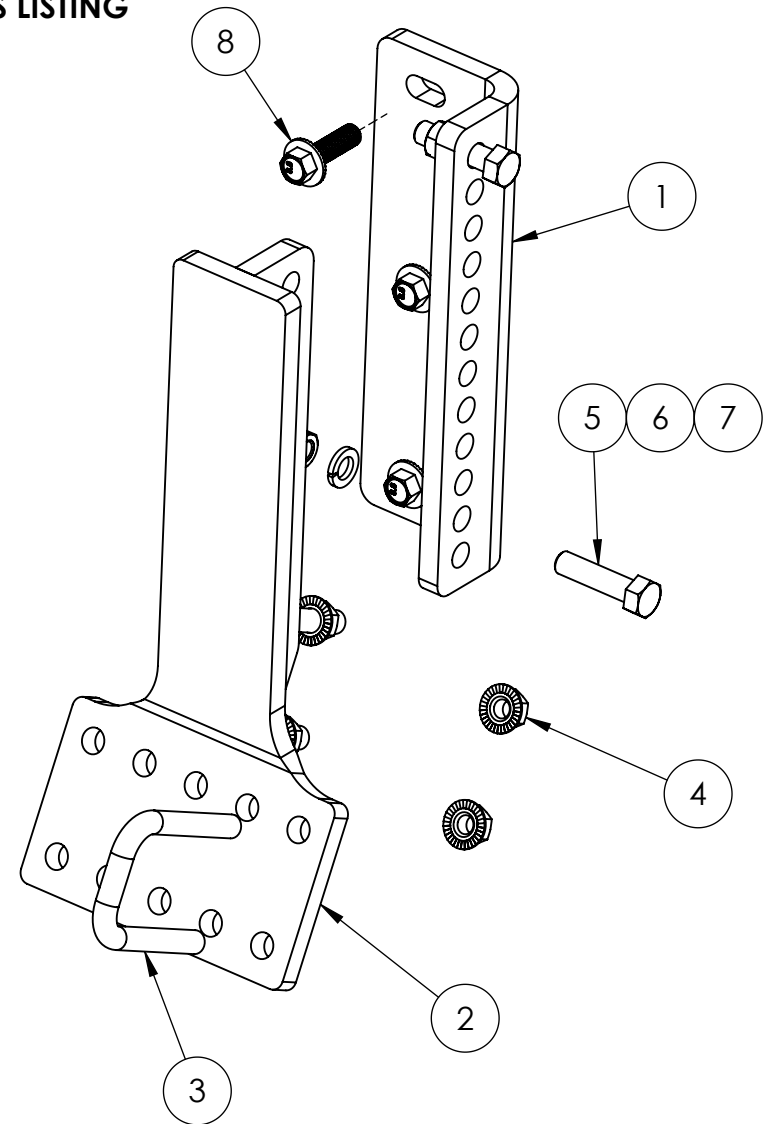

MAY WES
Original Poly People
A DIVISION OF PRIDE SOLUTIONS

120 Eastgate Drive SE
Hutchinson, MN 55350

1-800-788-6483
1-320-587-2322
1-320-587-6112 (Fax)

WWW.MAYWES.COM