

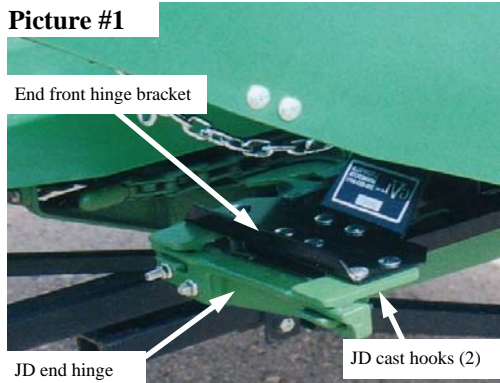

The Original Farmer Designed
59711 U.S. Hwy 12, Litchfield, MN 55355
1-888-485-8411

Assembly Instructions John Deere 40 Series 30 End Left GVL I (JD 46613L)

Picture #1



Picture #2



Picture #3

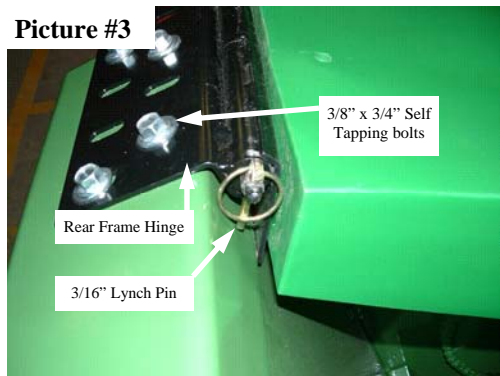

1. Remove the old metal Gatherer. (**For Low-tin Models: Keep JD cast hooks**)
2. Remove all support brackets and braces.
3. Install the end front hinge bracket to the front of **GVL** end main frame. (**Use 3/8" x 1" carriage bolts**) (**leave loose**) (**Picture #1**) (**ITEM # 9**)
4. Install JD cast hooks on the end front hinge bracket. (**leave loose**) **Hi-tin for JD models** do not hinge forward, they are bolted solid. To convert over to the **GVL** ends you must purchase and install hooks and hinges from your John Deere Dealer.
 - 2) Hooks-part #H113237 (per end)
 - 1) Right end hinge-part #H109940 (per end)
 - 1) Left end hinge-part #H109941 (per end)
5. Mount the rear gatherer hinge using three 3/8" x 2" carriage bolts, washers and nylon lock nuts. (Leave loose) (**Picture #2**) (**ITEM # 7**)
6. Install the **GVL** Gatherer Shield in the front. (**Picture #1**)
7. Slide the frame with the gatherer shield back.
8. Assemble the Rear Frame Hinge with the long L-shaped pin (**ITEM # 8**) and secure it with the 3/16" lynch pin. (**Picture #3**)
9. Position and align the gatherer.
10. Position the Hinge on top of the rear tube and drill 5/16" holes.
11. Fasten the Rear Hinge to the frame with 3/8" x 3/4" self tapping hex head bolts. (Provided) (**Picture #3**) (**ITEM # 6**)
12. **TIGHTEN ALL THE BOLTS AND NUTS.**
13. Install the front snout (**ITEM # 2**) using the 12 x 150 mm head bolts. (Make sure the 1/2" washers are placed on the bolt before putting them through the hole in the plastic.)

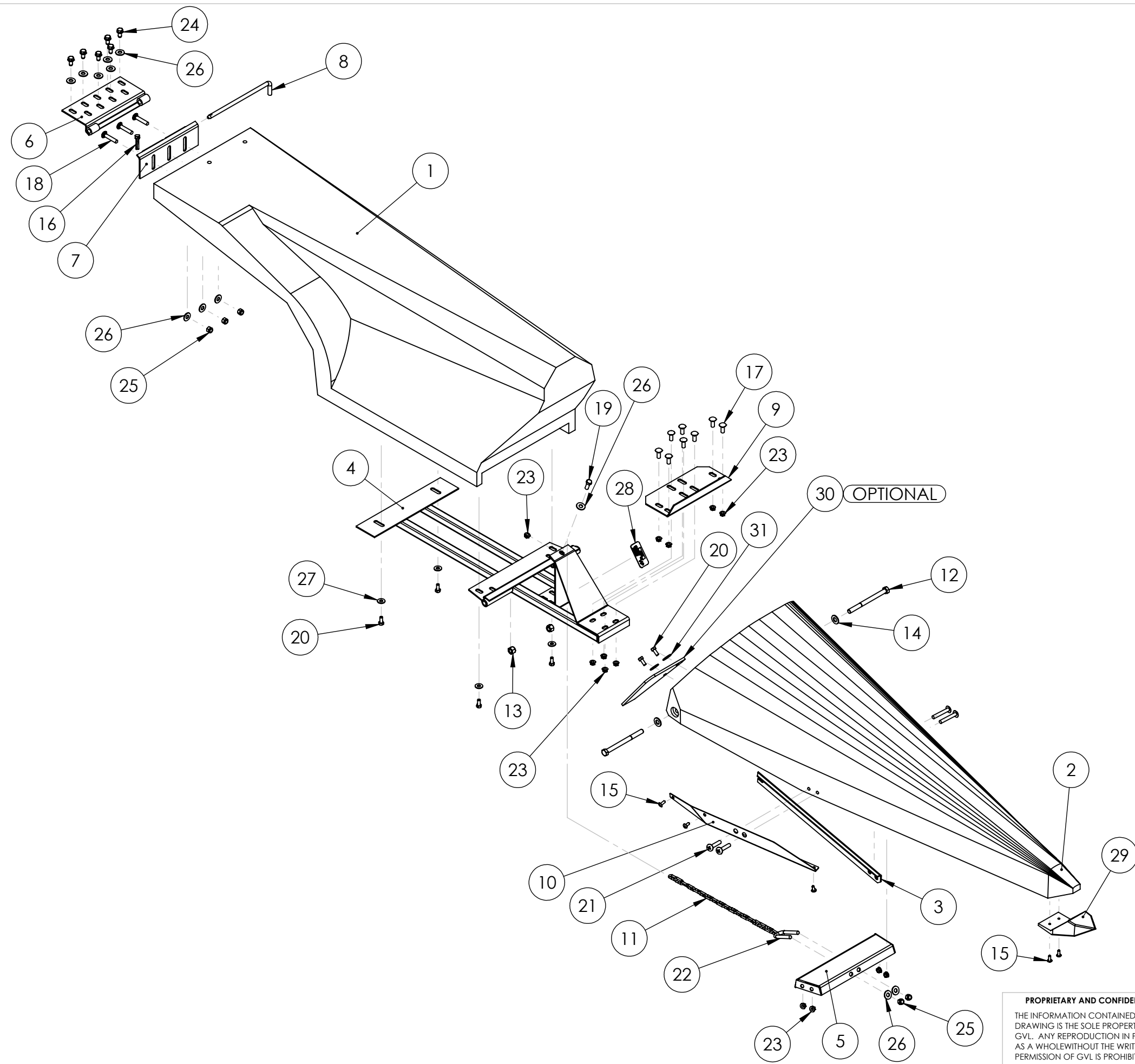

ITEM NO.	PART NUMBER	DESCRIPTION	QTY.
1	GN 16611-L	30's END LEFT BACK LONG MF RED	1
2	GN 16600	30's LEFT END GREEN	1
3	UN 00004	STIFFENER-LEFT FRONT	1
4	UN 16702	UNI END MAIN FRAME-30	1
5	UN 16603	FRT ADJ GATH BRKT-30 LEFT END	1
6	JD 46724	REAR FRAME HINGE	1
7	JD 46725	REAR GATHERER HINGE	1
8	JD 46726	HINGE PIN ENDS	1
9	JD 46712	FRONT HINGING BRACKET	1
10	UN 21004	SS W STRIP-RIGHT EDGE 30'S END	1
11	PCC-316	3/16" PROOF CHAIN 21 LINK	1
12	12-150 MHB	12X150MM HX HD METRIC BOLT	2
13	12-MLN	12mm METRIC LOCK NUT	2
14	12-W SAE	1/2" SAE WASHER	2
15	14-34 TTS	1/4"x3/4" SELF TAP SCREW	5
16	316-LP	3/16" LYNCH PIN	1
17	38-1 CB	3/8"x1" CARR BOLT-SHORT NECK	8
18	38-2 CB	3/8"x2 CARR BOLT	3
19	38-1 HB	3/8"x1" HX HD BOLT	1
20	516-34 HB	5/16"x3/4" HX HD BOLT	6
21	38-134 THB	3/8" X 1-3/4" PHILLIPS TRUSS HEAD BOLT	4
22	38-3 UB	3/8" X 3" U-BOLT	1
23	38-FSN	3/8" FLANGE SERRATED NUT	13
24	38-34 HWH	3/8"x 3/4" SELF TAP HEX HB	6
25	38-NLN	3/8" NYLON LOCK NUT	5
26	38-W USS	3/8" USS FLAT WASHER	12
27	516-W USS	5/16" USS WASHER	4
28	SN-531	SERIAL NUMBER TAG	1
29	WP-96	WHITE WEAR POINT	1
30	ESB-GVL	GVL EAR SAVER	1
31	516-W F	5/16 FENDER WASHER	2

	NAME	DATE
DRAWN	ALS	4/16/08
REVISED	MLB	11-16-12
ENG APPR.		
MFG APPR.		
Q.A.		
COMMENTS:		

GVL POLY

TITLE:
**JD 30's LEFT END
40 SERIES GVL I**

SIZE	DWG. NO.	REV
B	JD 46613L	A

SCALE: 1:12 WEIGHT: SHEET 1 OF 1

PROPRIETARY AND CONFIDENTIAL
THE INFORMATION CONTAINED IN THIS DRAWING IS THE SOLE PROPERTY OF GVL. ANY REPRODUCTION IN PART OR AS A WHOLE WITHOUT THE WRITTEN PERMISSION OF GVL IS PROHIBITED.