



The Original Farmer Designed
59711 U.S. Hwy 12, Litchfield, MN 55355
1-888-485-8411

Assembly Instructions

AGCO 3000

30" Center

(3016)

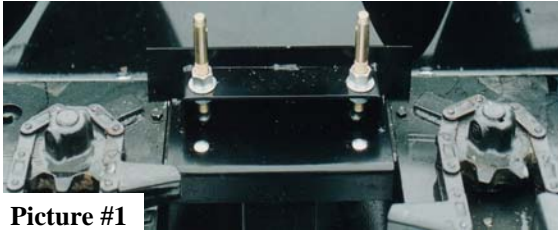

Picture #1

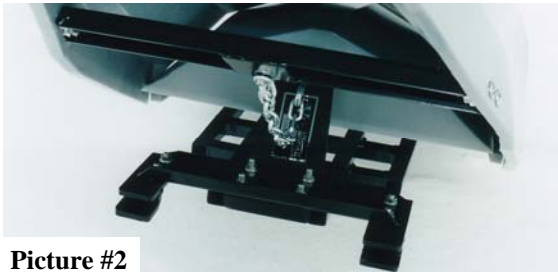

Picture #2



Picture #3



Picture #4



Picture #5



Picture #6



Picture #7

1. Remove filler plate between the row units and replace with **GVL** rear hold-down bracket (**Item #8**) using (4) 5/16" x 3/4" carriage bolts and nuts. (**Center and Tighten**) (**Picture #1**)
2. Install the front hinge bracket (**Item #9**) to the front of the **GVL** main frame (**Item #3**) using 3/8" x 1" carriage bolts and nuts provides. (**Leave Loose**)
3. Install the hooks (**Item #13**) on the front hinge bracket using 3/8" x 1" carriage bolts and nut provided. (**Leave Loose**) (**Picture #2**)
4. Bolt Hinging Bracket Mounting Angle (**Item #10**) in the 1/2" holes that are normally used to hold the original hinge bracket. (Use 2 hole side of bracket) **Note:** May have to grind small upper lip on Row Unit. (**Picture #3**)
5. Bolt Front Hinging Bracket Mounting Plate (**Item #11**) to Mounting Angle (**Item #10**). (Use front 2 holes) using 1/2" x 1" carriage bolts and flange nuts. (Center and align plate between row units and tighten bolts. (**Picture #3 & #4**)
6. Bolt Lower Hinging Bracket (**Item #12**) to the Front Hinging Bracket Mounting Plate (**Item #11**) using 1/2" x 1" carriage bolts and flange nuts. (**Leave Loose**) (**Picture #5**)
7. Set the **GVL** Gatherer Shields in place inserting the hook end first. (**Picture #6**) Next tilt the back down through the rear hold-down pins. (**Item #34**) The pins are tapered to self align. (**Picture #7**)
8. Position the Gatherer Shield and tighten the bolts.
9. Adjust the rear hold-down pins up or down so the lynch pins (**Item #15**) are snug (**The 5/8" washers are for under the lynch pins**), then tighten hold-down pin nuts. (**Picture #7**)
10. The PVC pipe around the adjustment chain. (**Must be removed.**) (**For shipping only**)

ITEM NO.	PART NUMBER	DESCRIPTION	QTY.	ITEM NO.	PART NUMBER	DESCRIPTION	QTY.
37	SN-531	SERIAL NUMBER TAG	1	1	XX 03001	30" CENTER BACK	1
38	WP-96	Wear Point	1	2	XX 13000	30" CENTER GATHERER FRONT	1
39	ES-GVL	GVL EAR SAVER	2	3	DA 13002	30" MAIN FRAME	1
40	516-W F	5/16 FENDER WASHER	4	4	UN 00006	5/8" JAM NUT PLATE	2
				5	UN 13003	30" FRONT GATH BRKT	1
				6	UN 21001	SS WEAR SRTIPS-LEFT EDGE	1
				7	UN 21002	SS WEAR SRTIPS-RIGHT EDGE	1
				8	DA 03004	30" REAR HOLD DN BRKT	1
				9	DA 03012	30" FRT HINGING BRKT	1
				10	DA 02022	HINGING BRACKET MOUNTING ANGLE	2
				11	DA 03018	30" FRONT HINGING BRKT MOUNTING PLATE	1
				12	DA 03019	22" LOWER HINGING BRACKET	1
				13	DA 00009	HOOK-HUGGER SERIES	2
				14	14-34 TTS	1/4"x3/4" TR TAPPING SCREW	10
				15	14-LP	1/4" LYNCH PIN	2
				16	516-34 CB	5/16"x3/4" CARRAGE BOLT	4
				17	516-34 HB	5/16"x3/4" HX HD BOLT	9
				18	516-FSN	5/16" FLANGE SERRATED NUT	4
				19	516-W USS	5/16" USS FLAT WASHER	5
				20	38-1 CB	3/8"x1" CARR BOLT-SHORT NECK	8
				21	38-1 HB	3/8"x1" HX HD BOLT	1
				22	38-W USS	3/8" USS FLAT WASHER	3
				23	38-134 THB	3/8"x1 3/4" TRUSS HEAD BOLT	4
				24	38-3 UB	3/8"x3" U-BOLT	1
				25	38-FSN	3/8" FLANGE SERRATED NUT	13
				26	38-NLN	3/8" NYLON LOCK NUT	2
				27	12-1 CB	1/2" X 1" CARR BOLT	8
				28	12-114 HB	1/2"x1 1/4" HX HD BOLT	4
				29	12-150 MHB	12X150 HX HD METRIC BOLT	2
				30	12-MLN	12 METRIC LOCK NUT	2
				31	12-FSN	1/2" FLANGE SERRATED NUT	8
				32	12-W SAE	1/2" SAE WASHER	6
				33	58-W SAE	5/8" SAE WASHER	4
				34	58-4 HDP	5/8"x4" LG HOLD DOWN PIN	2
				35	58-FTN	5/8" FINE THREAD NUT	2
				36	PCC-316	3/16 PROOF COIL CHAIN	19

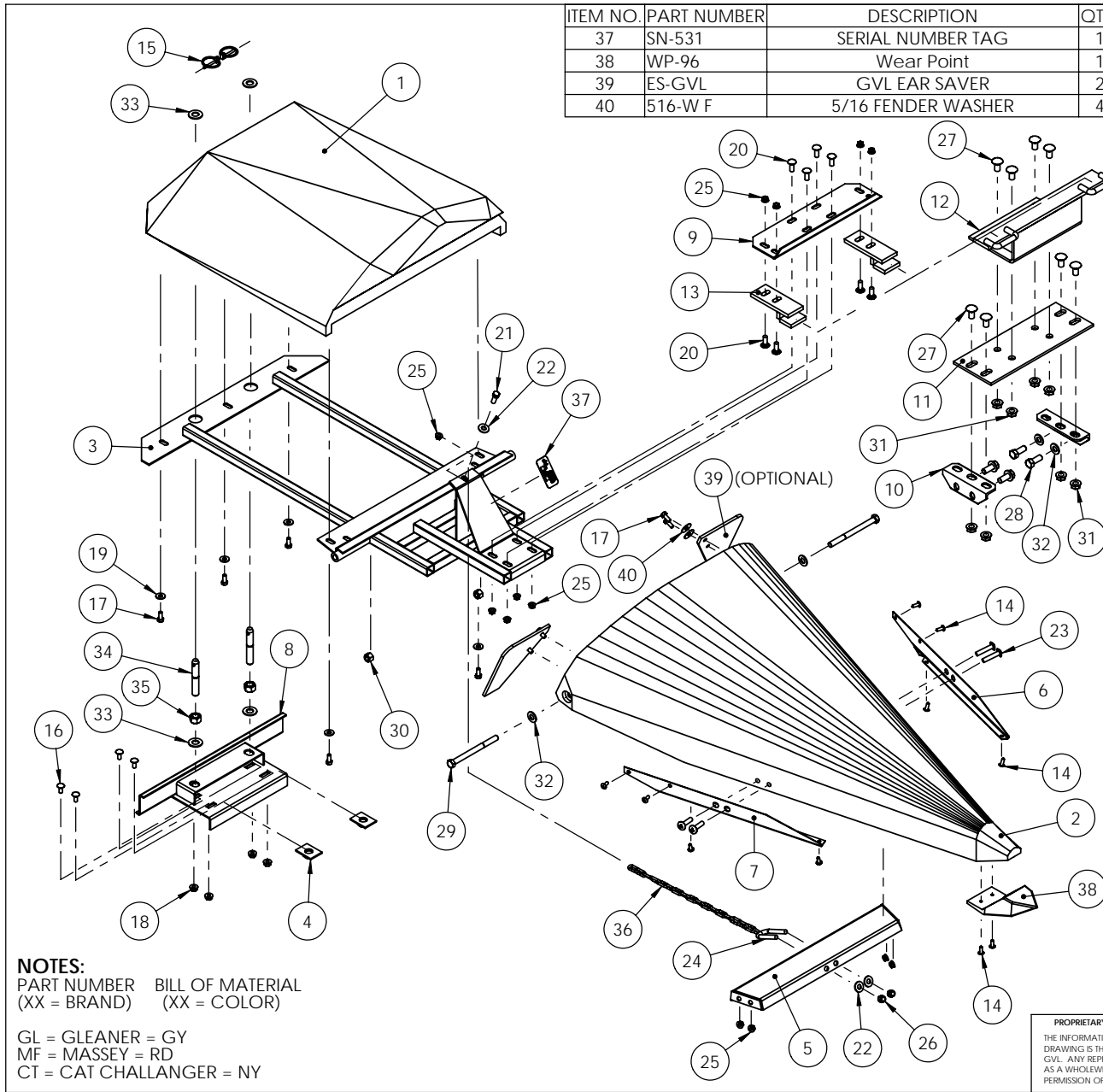

NOTES:
PART NUMBER BILL OF MATERIAL
(XX = BRAND) (XX = COLOR)

GL = GLEANER = GY
MF = MASSEY = RD
CT = CAT CHALLENGER = NY

PROPRIETARY AND CONFIDENTIAL
THE INFORMATION CONTAINED IN THIS
DRAWING IS THE SOLE PROPERTY OF
GVL. ANY REPRODUCTION IN PART OR
AS A WHOLE WITHOUT THE WRITTEN
PERMISSION OF GVL IS PROHIBITED.

NAME	DATE	GVL	
DRAWN: ALS	5/30/08	TITLE: AGCO 3000 30" CENTER GVL I	
CHECKED:		SIZE: B	DWG. NO.: XX 3016
ENG APPR.:		SCALE: 1:10	REV
MFG APPR.:		WEIGHT:	SHEET 1 OF 1
Q.A.:			
COMMENTS:			